

SMPTE RECOMMENDED PRACTICE

4:2:2 / 4:2:0 Format Conversion Minimizing Color Difference Signal Degradation in Concatenated Operations — Filtering



Table of Contents	Page
Foreword	2
Intellectual Property	2
Introduction	2
1 Scope	5
2 Conformance Notation	5
3 Normative References	5
4 Filtering Overview	6
5 Filtering Coefficients for 4:2:2 and 4:2:0 Inter-format Sampling System	6
5.1 Definitions	6
5.2 Filter Coefficients	6
Annex A Bibliography (Informative)	11

Foreword

SMPTE (the Society of Motion Picture and Television Engineers) is an internationally-recognized standards developing organization. Headquartered and incorporated in the United States of America, SMPTE has members in over 80 countries on six continents. SMPTE's Engineering Documents, including Standards, Recommended Practices, and Engineering Guidelines, are prepared by SMPTE's Technology Committees. Participation in these Committees is open to all with a bona fide interest in their work. SMPTE cooperates closely with other standards-developing organizations, including ISO, IEC and ITU.

SMPTE Engineering Documents are drafted in accordance with the rules given in Part XIII of its Administrative Practices.

SMPTE RP 2050-1 was prepared by Technology Committee 32NF.

Intellectual Property

SMPTE draws attention to the fact that it is claimed that compliance with this Standard may involve the use of one or more patents or other intellectual property rights (collectively, "IPR"). The Society takes no position concerning the evidence, validity, or scope of this IPR.

Each holder of claimed IPR has assured the Society that it is willing to License all IPR it owns, and any third party IPR it has the right to sublicense, that is essential to the implementation of this Standard to those (Members and non-Members alike) desiring to implement this Standard under reasonable terms and conditions, demonstrably free of discrimination. Each holder of claimed IPR has filed a statement to such effect with SMPTE. Information may be obtained from the Director, Standards & Engineering at SMPTE Headquarters.

Attention is also drawn to the possibility that elements of this Standard may be subject to IPR other than those identified above. The Society shall not be responsible for identifying any or all such IPR.

Introduction

This section is entirely informative and does not form an integral part of this Recommended Practice.

The 4:2:0 format is widely used in H.262/MPEG-2, H.264/MPEG-4 Part 10 and VC-1 compression. When a 4:2:0 video decoder and encoder are connected via a 4:2:2 serial interface such as SMPTE ST 292-1, the 4:2:0 data is decoded and converted to 4:2:2 by up-sampling the color difference component. In the 4:2:0 video encoder, the 4:2:2 video data is converted to 4:2:0 video data by down-sampling the color difference component. In this case, there typically exists a color difference mismatch between the 4:2:0 video data from the decoder and the 4:2:0 video data to be encoded (see Figure 1)

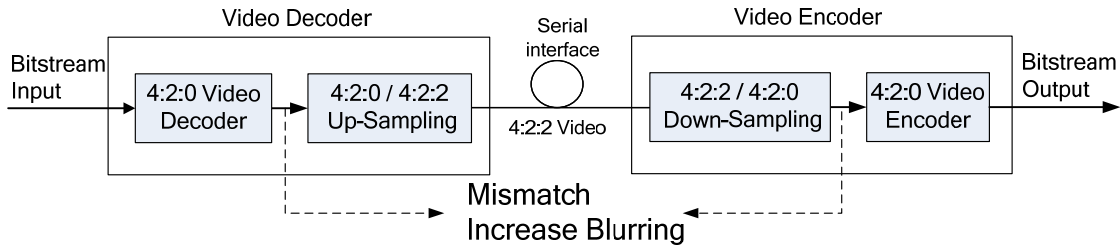

Figure 1 – Connection of 4:2:0 Decoder and Encoder for concatenation

Several stages of codec concatenation are common through the video processing chain. As a result, color difference signal mismatch between 4:2:0 video data input to 4:2:0 video encoder and 4:2:0 video output from 4:2:0 video decoder is accumulated and the degradation becomes visible (see Figure 2).

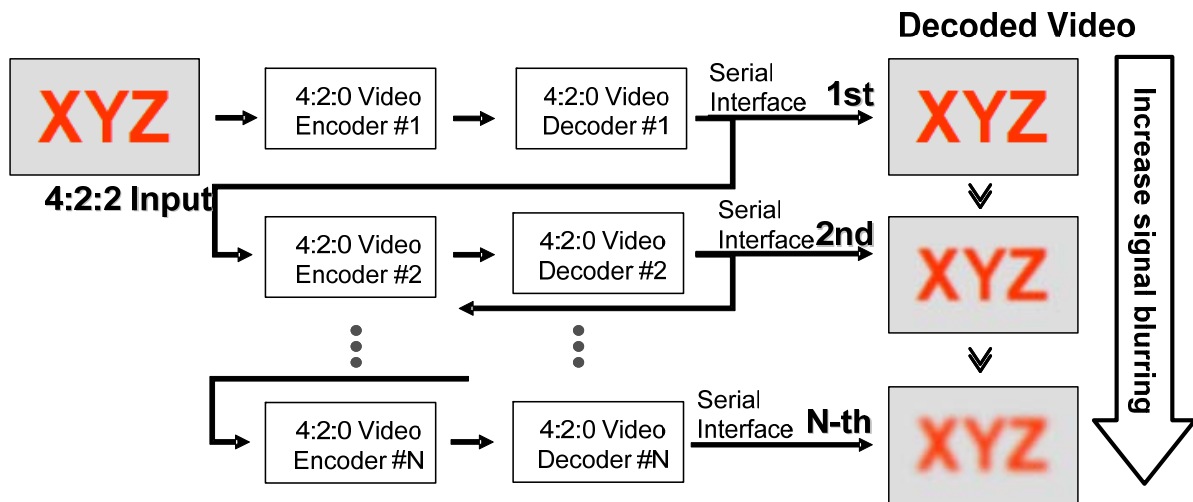

Figure 2 – Conceptual diagram of color difference degradation after codec concatenation

This document defines filter coefficient sets of 4:2:2/4:2:0 and 4:2:0/4:2:2 inter-format conversion to minimize degradation caused by concatenation. This is achieved by making the 4:2:2/4:2:0 inter-format filter sets satisfy complementing reconstruction filters. The use of these filter coefficients preserves the color difference signal resolution of the first 4:2:0 sub-sampling (see Figure 3).

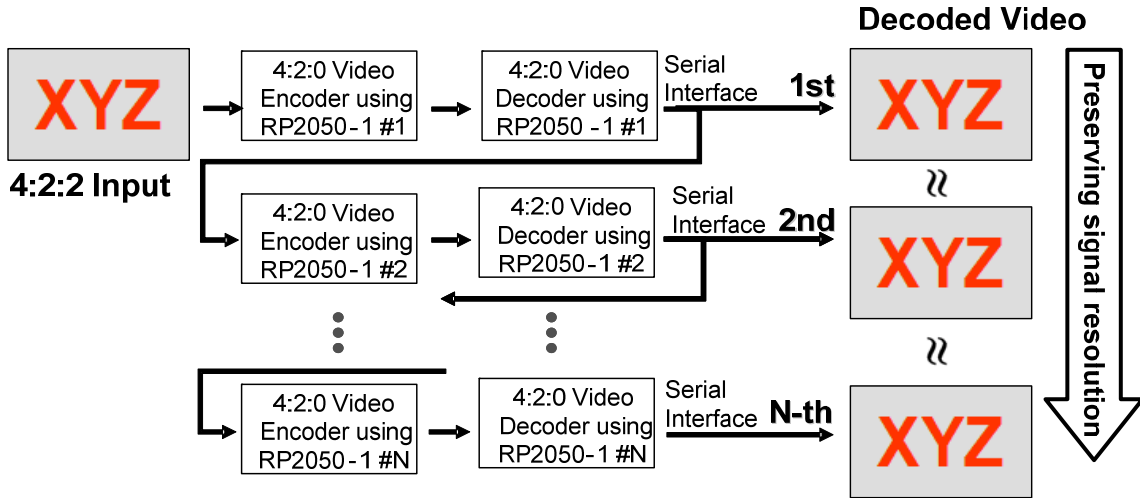

Figure 3 – Conceptual diagram of minimizing color difference signal degradation

Compatibility with filters not using the coefficients set is maintained with minimum degradation (see Figure 4).

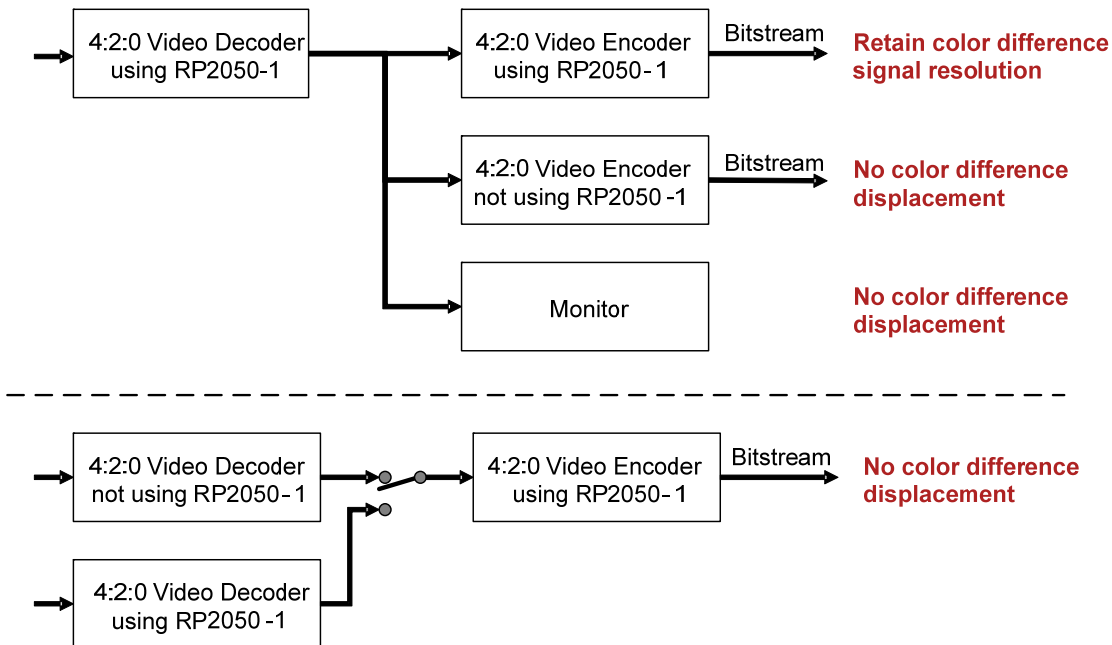

Figure 4 – Compatibility with conventional 4:2:0 and 4:2:2 equipment

It is noted that there is no benefit to using the filter sets defined in this document in an application when the output is not re-encoded.

1 Scope

This document defines filter coefficient sets for high-definition television format conversion between 4:2:2 image sampling and 4:2:0 image sampling for progressive and interlace images. The coefficients are applicable to a maximum 10 bit system.

2 Conformance Notation

Normative text is text that describes elements of the design that are indispensable or contains the conformance language keywords: "shall", "should", or "may". Informative text is text that is potentially helpful to the user, but not indispensable, and can be removed, changed, or added editorially without affecting interoperability. Informative text does not contain any conformance keywords.

All text in this document is, by default, normative, except: the Introduction, any section explicitly labeled as "Informative" or individual paragraphs that start with "Note:"

The keywords "shall" and "shall not" indicate requirements strictly to be followed in order to conform to the document and from which no deviation is permitted.

The keywords, "should" and "should not" indicate that, among several possibilities, one is recommended as particularly suitable, without mentioning or excluding others; or that a certain course of action is preferred but not necessarily required; or that (in the negative form) a certain possibility or course of action is deprecated but not prohibited.

The keywords "may" and "need not" indicate courses of action permissible within the limits of the document.

The keyword "reserved" indicates a provision that is not defined at this time, shall not be used, and may be defined in the future. The keyword "forbidden" indicates "reserved" and in addition indicates that the provision will never be defined in the future.

A conformant implementation according to this document is one that includes all mandatory provisions ("shall") and, if implemented, all recommended provisions ("should") as described. A conformant implementation need not implement optional provisions ("may") and need not implement them as described.

Unless otherwise specified, the order of precedence of the types of normative information in this document shall be as follows: Normative prose shall be the authoritative definition; Tables shall be next; followed by formal languages; then figures; and then any other language forms.

3 Normative References

The following standards contain provisions which, through reference in this text, constitute provisions of this recommended practice. At the time of publication, the editions indicated were valid. All standards are subject to revision, and parties to agreements based on this recommended practice are encouraged to investigate the possibility of applying the most recent edition of the standards indicated below.

No normative references are specified for implementation of this document.

4 Filtering Overview

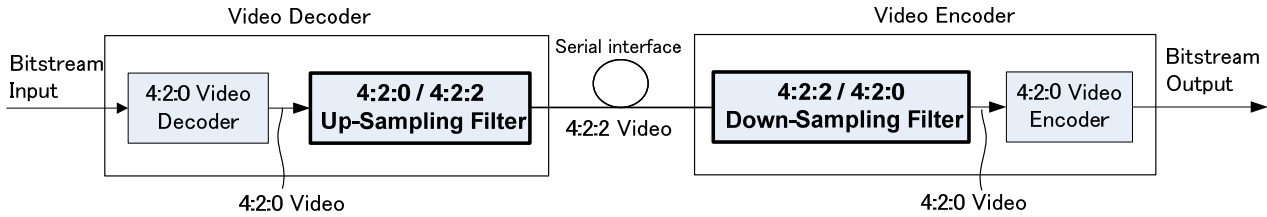

Figure 5 – Overview of Filtering

Figure 5 shows the overview of the filtering defined in this document.

When a 4:2:0 video decoder and encoder are connected via a serial interface, 4:2:0 data is decoded and the data is converted to 4:2:2 by up-sampling the color difference component, and then the 4:2:2 video data is mapped onto a serial interface. In the 4:2:0 video encoder, the 4:2:2 video data from the serial interface is converted to 4:2:0 video data by down-sampling the color difference component.

This document defines filter coefficient sets for 4:2:0/4:2:2 up-sampling and filter coefficient sets for 4:2:2/4:2:0 down-sampling, to provide minimally degraded 4:2:0 color difference signals in concatenated operations.

Note: An example implementation of the filter sets defined in this document is described in SMPTE EG 2050-2.

5 Filtering Coefficients for 4:2:2 and 4:2:0 Inter-format Sampling System

5.1 Definitions

The following nomenclature is used in this document.

F0[-3]...F[4]: Filter coefficients for conversion from 4:2:2 to 4:2:0.

F1e[-1]...F1e[2], F1o[-1]...F1o[2]: Filter coefficients from 4:2:0 to 4:2:2.

Divisor: A value equal to the sum of the filter coefficients to maintain unity gain through the filter.

Even Line: even numbered active line of a progressive image, and even numbered active line in the first and second field of an interlaced image. For progressive images, the line number zero corresponds to the first active line of the progressive image. For the first field of an interlaced image, the line number zero corresponds to the first active line. For the second field of an interlaced image, the line number zero corresponds to the first active line.

Odd Line: odd numbered active line of a progressive image, and odd numbered active line in the first and second field of an interlaced image.

5.2 Filter Coefficients

This section defines the filter coefficients for down-sampling from 4:2:2 to 4:2:0 and up-sampling from 4:2:0 to 4:2:2.

5.2.1 Progressive Images

Figure 6 shows a mapping of 4:2:2 and 4:2:0 samples for the filter coefficients of progressive image format.

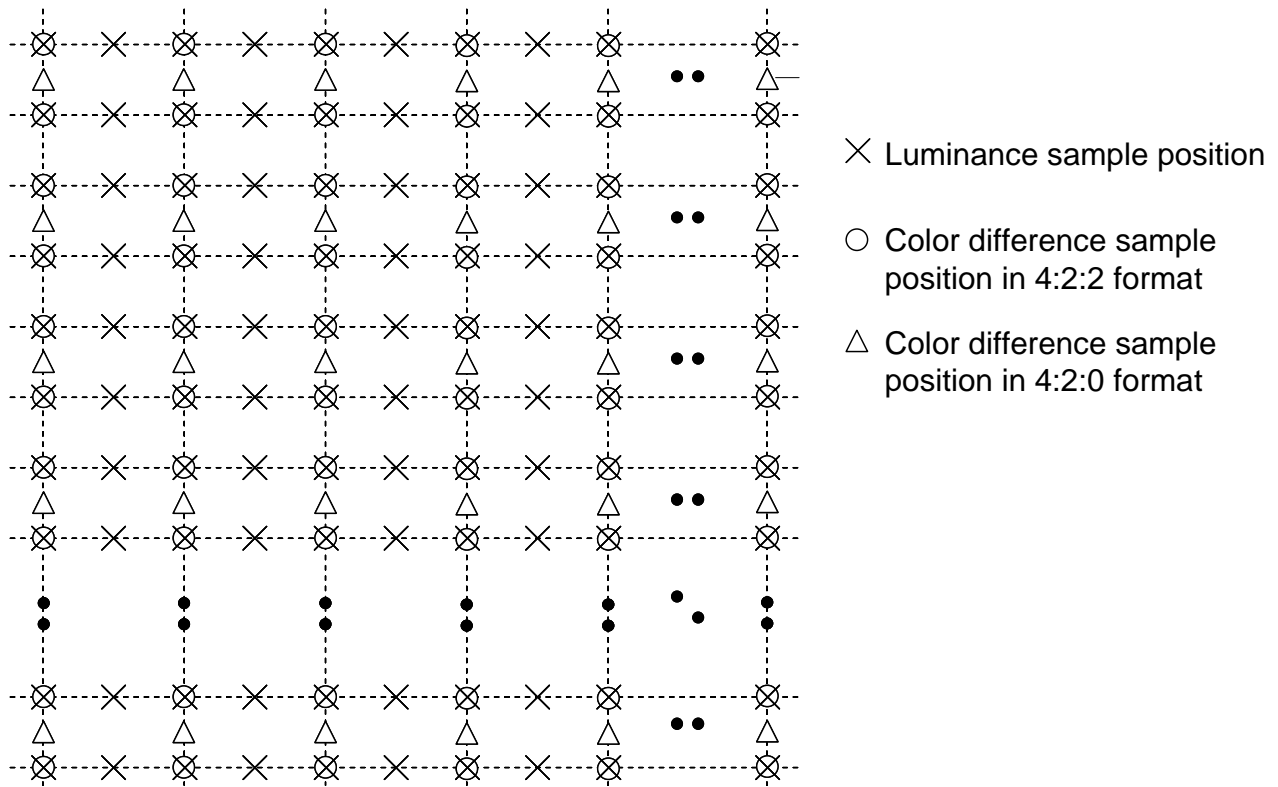

Figure 6 – Mapping of 4:2:2 and 4:2:0 samples for the progressive image format

For the conversion from 4:2:2 to 4:2:0 of a progressive image, the filter coefficients defined in Table 1 shall be applied to the down-sampling procedure. The divisor shall be 1024.

Table 1 – Progressive image format filter coefficients for 4:2:2 / 4:2:0 conversion

Position	$F0[-3]$	$F0[-2]$	$F0[-1]$	$F0[0]$	$F0[1]$	$F0[2]$	$F0[3]$	$F0[4]$
Coefficients	-3	-19	34	500	500	34	-19	-3

For the conversion from 4:2:0 to 4:2:2 of a progressive image, the filter coefficients defined in Table 2 and Table 3 shall be applied to the up-sampling procedure. The divisor shall be 1024.

Table 2 – Progressive image format filter Coefficients for 4:2:0 / 4:2:2 conversion of Even Lines

Position	$F1e[-2]$	$F1e[-1]$	$F1e[0]$	$F1e[1]$
Coefficients	19	103	1037	-135

Table 3 – Progressive image format Filter Coefficients for 4:2:0 / 4:2:2 conversion of Odd Lines

Position	$F1o[-1]$	$F1o[0]$	$F1o[1]$	$F1o[2]$
Coefficients	-135	1037	103	19

5.2.2 Interlaced Images

5.2.2.1 First field of Interlaced Images

Figure 7 shows a mapping of 4:2:2 and 4:2:0 samples for the filter coefficients of the first field in the interlace image format.

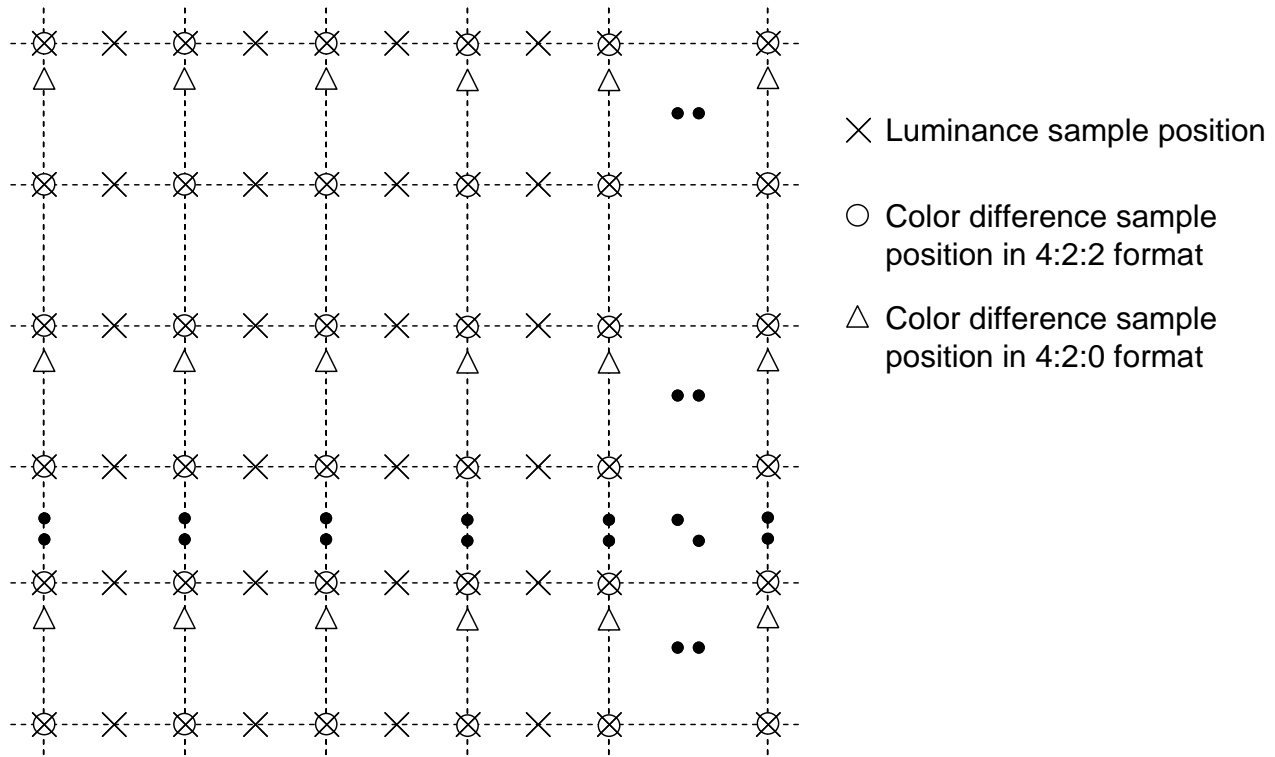

Figure 7 – Mapping of 4:2:2 and 4:2:0 samples for the first field of interlace image format

For the conversion from 4:2:2 to 4:2:0 of the first field an interlaced image, the filter coefficients defined in Table 4 shall be applied to the down-sampling procedure. The divisor shall be 1024.

Table 4 – Interlaced image format filter coefficients for 4:2:2 / 4:2:0 conversion for the first field

Position	$F0[-3]$	$F0[-2]$	$F0[-1]$	$F0[0]$	$F0[1]$	$F0[2]$	$F0[3]$	$F0[4]$
Coefficients	-8	-26	115	586	409	-48	-4	0

For the conversion from 4:2:0 to 4:2:2 of the first field of an interlaced image, the filter coefficients defined in Table 5 and Table 6 shall be applied to the up-sampling procedure. The divisor shall be 1024.

Table 5 – Interlaced image format filter Coefficients for 4:2:0 / 4:2:2 conversion for Even Lines of the first field

Position	$F1e[-2]$	$F1e[-1]$	$F1e[0]$	$F1e[1]$
Coefficients	24	-41	1169	-128

Table 6 – Interlaced image format filter Coefficients for 4:2:0 / 4:2:2 conversion for Odd Lines of the first field

Position	$F1o[-1]$	$F1o[0]$	$F1o[1]$	$F1o[2]$
Coefficients	-76	783	330	-13

5.2.2.2 Second Field of Interlaced Images

Figure shows a mapping of 4:2:2 and 4:2:0 samples for the filter coefficients of the first field in the interlace image format.

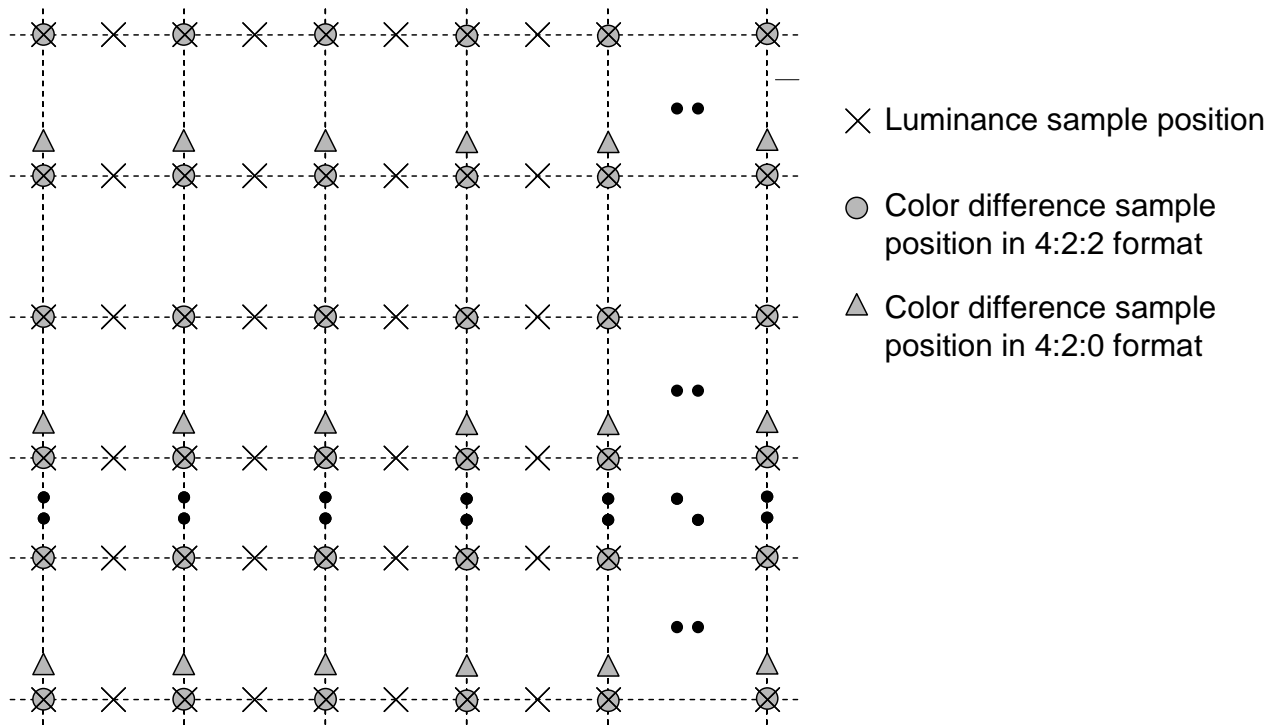

Figure 8 – Mapping of 4:2:2 and 4:2:0 samples for the second field of interlace image format

For the conversion from 4:2:2 to 4:2:0 of the second field of an interlaced image, the filter coefficients defined in Table 7 shall be applied to the down-sampling procedure. The divisor shall be 1024.

Table 7 – Interlaced image format filter coefficients for 4:2:2 / 4:2:0 conversion for the second field

Position	$F0[-3]$	$F0[-2]$	$F0[-1]$	$F0[0]$	$F0[1]$	$F0[2]$	$F0[3]$	$F0[4]$
Coefficients	0	-4	-48	409	586	115	-26	-8

For the conversion from 4:2:0 to 4:2:2 of the second field of an interlaced image, the filter coefficients defined in Table 8 and Table 9 shall be applied to the up-sampling procedure. The divisor shall be 1024.

Table 8 – Interlaced image format filter Coefficients for 4:2:0 / 4:2:2 conversion for Even Lines of the second field

Position	$F1e[-2]$	$F1e[-1]$	$F1e[0]$	$F1e[1]$
Coefficients	-13	330	783	-76

Table 9 – Interlaced image format filter Coefficients for 4:2:0 / 4:2:2 conversion for Odd Lines of the second field

Position	$F1o[-1]$	$F1o[0]$	$F1o[1]$	$F1o[2]$
Coefficients	-128	1169	-41	24

Annex A Bibliography (Informative)

Note: All references in this document to other SMPTE documents use the current numbering style (e.g. SMPTE ST 274:2008) although, during a transitional phase, the document as published (printed or PDF) may bear an older designation (such as SMPTE 274M-2008). Documents with the same root number (e.g. 274) and publication year (e.g. 2008) are functionally identical.

SMPTE ST 274:2008, Television — 1920 × 1080 Image Sample Structure, Digital Representation and Digital Timing Reference Sequences for Multiple Picture Rates

SMPTE ST 292-1:2012, 1.5 Gb/s Signal / Data Serial Interface

SMPTE ST 296:2011, 1280 × 720 Progressive Image Sample Structure — Analog and Digital Representation and Analog Interface

SMPTE ST 372:2011, Dual Link 1.5 Gb/s Digital Interface for 1920 × 1080 and 2048 × 1080 Picture Formats

SMPTE ST 421:2006, VC-1 Compressed Video Bitstream Format and Decoding Process

Amendment 1:2007 to SMPTE ST 421:2006

Amendment 2:2011 to SMPTE ST 421:2006

SMPTE ST 424:2006, Television — 3 Gb/s Signal / Data Serial Interface

SMPTE EG 2050-2:2012, 4:2:2 / 4:2:0 Format Conversion Minimizing Color Difference Signal Degradation in Concatenated Operations — Application

ISO/IEC 13818-2:2000, Information Technology — Generic Coding of Moving Pictures and Associated Audio Information: Video

ITU-T Recommendation H.264, Advanced Video Coding for Generic Audiovisual Services

“The 4:2:2/4:2:0 perfect reconstruction filter set and its application in HD-SNG”, SMPTE Motion Imaging Journal, pp29-39, July/August 2009