

# SMPTE STANDARD

## for Television — Time and Control Code



<b>Table of Contents</b>	<b>Page</b>
Foreword .....	4
Introduction .....	5
1 Scope .....	6
2 Conformance Notation .....	6
3 Normative References .....	7
4 Definitions .....	7
4.1 Time and Control Code .....	7
4.2 Linear Time Code (LTC) .....	7
4.3 Vertical Interval Time Code (VITC) .....	7
4.4 Ancillary Time Code (ATC) .....	8
4.5 Frame .....	8
4.6 Field .....	8
4.7 Time Code Source / Original Source .....	8
4.8 Binary Coded Decimal (BCD) System .....	8
4.9 Frame Rate .....	8
5 Time Representation in 30 and 60 Frames-Per-Second Systems .....	9
5.1 Definitions of Real Time and NTSC Time .....	9
5.1.1 Definition of real time .....	9
5.1.2 Definition of NTSC time .....	9
5.2 Time Address of a Frame .....	9
5.2.1 Non-drop frame – Uncompensated mode .....	9
5.2.2 Drop frame – NTSC time compensated mode .....	9
5.3 Color Frame Identification in NTSC Analog Composite Television Systems .....	10
6 Time Representation in 25 and 50 Frames-Per-Second Systems .....	10
6.1 Definitions of Real Time .....	10
6.2 Time Address of a Frame .....	10
6.3 Color Frame Identification in PAL Composite Television Systems .....	10
6.3.1 Logical relationship .....	11
6.3.2 Arithmetic relationship .....	11
7 Time Representation in 24 Frames-Per-Second Systems .....	11
7.1 Definitions of Real Time and NTSC Time .....	11
7.1.1 Definition of real time .....	11
7.1.2 Definition of NTSC time .....	11
7.2 Time Address of a Frame .....	12

- 8 Structure of the Time Address and Control Bits ..... 12
  - 8.1 Numeric Code..... 12
  - 8.2 Time Address..... 12
  - 8.3 Flag Bits..... 12
    - 8.3.1 Drop frame flag..... 12
    - 8.3.2 Color frame flag (NTSC and PAL composite color systems) ..... 12
    - 8.3.3 Binary group flags..... 12
    - 8.3.4 Modulation method specific flag ..... 13
  - 8.4 Use of the Binary Groups ..... 13
    - 8.4.1 Character set not specified and unspecified clock time (BGF2=0, BGF1=0, BGF0=0).... 13
    - 8.4.2 Eight-bit character set and unspecified clock time (BGF2=0, BGF1=0, BGF0=1)..... 13
    - 8.4.3 Character set not specified and clock time specified (BGF2=0, BGF1=1, BGF0=0)..... 13
    - 8.4.4 Reserved binary group usage and reserved clock time (BGF2=0, BGF1=1, BGF0=1).... 14
    - 8.4.5 Date/time zone and unspecified clock time (BGF2=1, BGF1=0, BGF0=0) ..... 14
    - 8.4.6 Page/line multiplex system and unspecified clock time (BGF2=1, BGF1=0, BGF0=1) .... 14
    - 8.4.7 Date/time zone and clock time (BGF2=1, BGF1=1, BGF0=0)..... 14
    - 8.4.8 Page/line multiplex system and clock time specified (BGF2=1, BGF1=1, BGF0=1) ..... 14
  - 8.5 Clock Time Reference – Binary Group Flag Combinations ..... 14
- 9 Linear Time Code Application ..... 14
  - 9.1 Codeword Format..... 14
  - 9.2 Codeword Data Content..... 14
    - 9.2.1 Time address..... 14
    - 9.2.2 Flag bits ..... 15
    - 9.2.3 Biphasic mark polarity correction..... 15
    - 9.2.4 Binary groups ..... 15
    - 9.2.5 Synchronization word ..... 16
  - 9.3 Modulation Method ..... 16
  - 9.4 Bit rate ..... 17
  - 9.5 Timing of the Codeword Relative to a Television Signal..... 17
  - 9.6 Linear Time Code Interface Electrical and Mechanical Characteristics ..... 18
    - 9.6.1 Rise/fall time ..... 18
    - 9.6.2 Amplitude distortion ..... 18
    - 9.6.3 Timing of the transitions ..... 18
    - 9.6.4 Interface connector (Informative) ..... 18
    - 9.6.5 Output impedance ..... 18
    - 9.6.6 Output amplitude (Informative)..... 18
- 10 Vertical Interval Application – Analog Television Systems..... 23
  - 10.1 Codeword Format..... 23
  - 10.2 Codeword Data Content..... 23
    - 10.2.1 Time address..... 26
    - 10.2.2 Flag bits ..... 26
    - 10.2.3 Binary groups ..... 26
    - 10.2.4 Field identification flag..... 27
    - 10.2.5 Synchronization bits ..... 27
    - 10.2.6 Cyclic redundancy check code..... 27
  - 10.3 Modulation Method ..... 28
  - 10.4 Bit Timing..... 28
  - 10.5 Timing of the Codeword Relative to the Television Signal..... 28
    - 10.5.1 525/59.94 television system ..... 28
    - 10.5.2 625/50 television system ..... 28
  - 10.6 Location of the VITC Codeword in the Vertical Interval ..... 29

10.6.1	525/59.94 television system.....	29
10.6.2	625/50 television system.....	29
10.6.3	Component television systems .....	29
10.7	Redundancy .....	29
10.8	Vertical Interval Time Code Waveform Characteristics .....	29
10.8.1	Logic level .....	29
10.8.2	Rise/fall time .....	30
10.8.3	Amplitude distortion .....	30
11	Relationship Between LTC and VITC .....	30
11.1	Time Address Data .....	30
11.2	Binary Group Data .....	30
11.2.1	Transferring VITC binary group data to LTC binary group data .....	30
11.2.2	Transferring LTC binary group data to VITC binary group data .....	30
11.3	VITC and LTC Codeword Comparison .....	30
12	Progressive Systems with Frame Rates Greater than 30 Frames Per Second .....	32
12.1	Time Address of a Frame Pair in 50 and 60 Frames-Per-Second Progressive Systems .....	32
12.2	Implementation Guidelines (Informative).....	33
Annex A	Explanatory Notes (Informative).....	34
A.1	Time Precision .....	34
A.2	Leap Second Corrections .....	34
A.3	Frames and Time Code .....	34
Annex B	Converting Time Codes when Converting Video from 24 Frames-Per-Second Television Systems (Informative).....	36
B.1	Conversion of 24/1.001 (23.98) Fps Video to 30/1.001 (29.97) Fps Video.....	36
B.2	Conversion of 24 Fps Video to 25 Fps Video.....	37
Annex C	Bibliography (Informative) .....	38
Annex D	Time Code System "Roadmap" (Informative) .....	40

## **Foreword**

SMPTE (the Society of Motion Picture and Television Engineers) is an internationally-recognized standards developing organization. Headquartered and incorporated in the United States of America, SMPTE has members in over 80 countries on six continents. SMPTE's Engineering Documents, including Standards, Recommended Practices and Engineering Guidelines, are prepared by SMPTE's Technology Committees. Participation in these Committees is open to all with a bona fide interest in their work. SMPTE cooperates closely with other standards-developing organizations, including ISO, IEC and ITU.

SMPTE Engineering Documents are drafted in accordance with the rules given in Part XIII of its Administrative Practices.

SMPTE Standard 12M-1 was prepared by Technology Committee S22.

## Introduction

This section is entirely informative and does not form an integral part of this document.

This standard is one of the oldest SMPTE Standards. It was first adopted in 1975, and it has been widely used for many systems outside SMPTE's normal area of purview. It was developed for analog television recording systems and thus dealt only with interlaced television systems operating with frame rates up to 30 frames per second. It is, however, flexible enough in design to be used in digital television systems, both standard definition and high definition. The actual transport of the codewords for digital systems varies significantly from the transport methods defined for analog systems, and is defined in the associated document, SMPTE 12M-2.

Progressive video systems with frame rates above 30 frames per second are described in this document, documenting what have become "de facto" implementations. Since the frame rate of these 50 and 60 frames-per-second progressive systems exceeds the frame count capacity of the time address, counting is done on frame pairs, which results in an edit resolution of two frames using traditional linear time code.

For applications of time code to film, SMPTE Recommended Practices RP 135 and RP 136 (see Annex C, Bibliography), which are similar to, but not the same as this standard, may be applied, in particular for in-camera optical recording.

Sections 5, 6, and 7 specify the manner in which time is represented in frame-based systems. Section 8 describes the structure of the time address and control bits of the code, and sets guidelines for storage of user data in the binary groups of the code. Section 9 specifies the modulation method and interface characteristics of a linear time code (LTC) source. Section 10 specifies the modulation method for inserting the code into the vertical interval of an analog television signal (VITC). Section 11 summarizes the relationship between the two forms of time and control code, LTC and VITC. Section 12 has been added to document time code implementations for video formats with frame per second rates greater than 30 fps.

The reader's attention is drawn to the following documentation changes from the prior SMPTE 12M-1999:

Two SMPTE Recommended Practices — RP 164-1996, Location of Vertical Interval Time Code and RP 159-1995, Vertical Interval Time Code and Longitudinal Time Code Relationship — have been consolidated into this document. The LTC reference datum has been relocated to the beginning of Vertical Sync from a location one horizontal line later. This change includes a widening of the tolerance interval to include the previous location tolerance interval

The time code documents have been restructured and organized into a suite of documents:

SMPTE 12M-1 (previously SMPTE 12M), including the revisions described above.

SMPTE 12M-2 (previously SMPTE RP 188), Ancillary Time Code.

## 1 Scope

This Standard specifies a time and control code for use in television and accompanying audio systems operating at nominal rates<sup>1</sup> of 60, 59.94, 50, 30, 29.97, 25, 24, and 23.98 frames per second. This standard defines a time address, binary groups, and flag bit structure. The standard also defines a binary group flag assignment, a linear time code transport, and a vertical interval time code transport.

This standard defines primary data transport structures for Linear Time Code (LTC) and Vertical Interval Time Code (VITC). This standard defines the LTC modulation and timing for all video formats. This standard also defines the VITC modulation and location for 525/59.94 and 625/50 analog composite and component systems only.

Note: The digital representation of analog VITC (D-VITC) is specified in SMPTE 266M and is defined for 525/59.94 and 625/50 digital component systems only. High Definition formats, such as those documented in SMPTE 274M and SMPTE 296M, should use Ancillary Time Code (ATC) as specified in SMPTE 12M-2 (formerly SMPTE RP 188) for transport of time code in the digital video data stream. For future implementations of time code for digital Standard Definition formats, the use of ATC rather than D-VITC is encouraged.

## 2 Conformance Notation

Normative text is text that describes elements of the design that are indispensable or contains the conformance language keywords: "shall", "should", or "may". Informative text is text that is potentially helpful to the user, but not indispensable, and can be removed, changed, or added editorially without affecting interoperability. Informative text does not contain any conformance keywords.

All text in this document is, by default, normative, except: the Introduction, any section explicitly labeled as "Informative" or individual paragraphs that start with "Note:"

The keywords "shall" and "shall not" indicate requirements strictly to be followed in order to conform to the document and from which no deviation is permitted.

The keywords, "should" and "should not" indicate that, among several possibilities, one is recommended as particularly suitable, without mentioning or excluding others; or that a certain course of action is preferred but not necessarily required; or that (in the negative form) a certain possibility or course of action is deprecated but not prohibited.

The keywords "may" and "need not" indicate courses of action permissible within the limits of the document.

The keyword "reserved" indicates a provision that is not defined at this time, shall not be used, and may be defined in the future. The keyword "forbidden" indicates "reserved" and in addition indicates that the provision will never be defined in the future.

A conformant implementation according to this document is one that includes all mandatory provisions ("shall") and, if implemented, all recommended provisions ("should") as described. A conformant implementation need not implement optional provisions ("may") and need not implement them as described.

---

<sup>1</sup>The reader is cautioned that non-integer values are abbreviated. These abbreviations may be seen throughout this document. See § 5.1.2 for additional information.

### 3 Normative References

The following standards contain provisions which, through reference in this text, constitute provisions of this standard. At the time of publication, the editions indicated were valid. All standards are subject to revision, and parties to agreements based on this standard are encouraged to investigate the possibility of applying the most recent edition of the standards indicated below.

ISO/IEC 646:1991, Information technology — ISO 7-bit coded character set for information interchange

ISO/IEC 2022:1994, Information technology — Character code structure and extension techniques

ITU-R BT.1700-1(2005), Annex 2, Characteristics of composite video signals for conventional analogue television systems

SMPTE 170M-2004, Television — Composite Analog Video Signal — NTSC for Studio Applications

SMPTE 262M-1995, Television, Audio and Film — Binary Groups of Time and Control Codes — Storage and Transmission of Data

SMPTE 309M-1999 Television — Transmission of Date and Time Zone Information in Binary Groups of Time and Control Code

SMPTE RP 168-2002, Definition of Vertical Interval Switching Point for Synchronous Video Switching

### 4 Definitions

#### 4.1 Time and Control Code

The term “time and control code” encompasses all aspects of the time address, flag bits, and binary groups for user-defined data codes, as well as two methods of modulation of the resulting codewords. It is commonly abbreviated to simply “time code” (note that some users spell this “timecode”).

Note: The time address and binary group (“user data”) payload is attached to a particular frame or frame pairs either directly or by reference within the user’s system. For frame-based systems the time address that forms part of the time code is primarily intended as a label to identify discrete frames. It also may imply that a particular frame has had, has now, or will have, a temporal relationship to something else, such as the frame's position in a sequence of frames or synchronization to a reference signal.

#### 4.2 Linear Time Code (LTC)

The acronym LTC refers to Linear Time Code, a codeword format and modulation system which is normally used to record the time code signal on a linear recording medium or to transport the serial signal over an interface independent of any video signal.

Note: LTC was, in earlier editions of this standard, referred to as the longitudinal track application of time and control code. The LTC codeword data is also used in digital television systems as Ancillary Time Code (see below).

#### 4.3 Vertical Interval Time Code (VITC)

The acronym VITC refers to the codeword format and modulation system used to insert the time code signal in an active line within the vertical blanking interval of an analog Standard Definition television (SDTV) signal.

Note: The VITC codeword data is also used in digital television systems as Ancillary Time Code (see below).

#### 4.4 Ancillary Time Code (ATC)

The acronym ATC refers to ancillary packets carried in the Ancillary space (VANC or HANC) of a digital television data stream, as described in SMPTE 12M-2 (formerly SMPTE RP 188), and payloads of these packets convey LTC or VITC codeword data.

Note: ATC may also be used to carry other user-defined information, such as real time clock, film transfer information, or tape timer information. ATC is a data transport applicable to both High Definition television (HDTV) and SDTV digital video formats.

#### 4.5 Frame

A frame contains all of the lines of spatial information of a video signal required to make up one complete picture (including any necessary associated synchronization lines). For progressive video, these lines contain picture samples, captured at one time instant, starting from the top of the frame and continuing through successive lines to the bottom of the frame.

#### 4.6 Field

For interlaced video, a frame consists of two fields. One of these fields will commence one field period later than the other.

Note: See SMPTE 170M for an example of such a system. Composite television standards might require multiple fields in a "color sequence," but that does not alter this document's nominal terminology.

#### 4.7 Time Code Source/Original Source

A Time Code Source is any device which generates a time and control code signal, or regenerates a time and control code signal from a recorded medium or transmission channel.

An Original Source refers specifically to a device which is generating the time and control code signal in synchronization with its associated video and/or audio.

Note: An example of such an Original Source is a video server or a videotape transport at play speed only. A videotape transport in shuttle would not qualify by this definition as an "Original Source."

#### 4.8 Binary Coded Decimal (BCD) system

A means for encoding decimal numbers as groups of binary bits. Each decimal digit (0-9) is represented by a unique four-bit code. The four bits are weighted with the digit's decimal weight multiplied by successive powers of two.

Note: For example, the bit weights for a "units" digit would be  $1 \times 2^0$ ,  $1 \times 2^1$ ,  $1 \times 2^2$ , and  $1 \times 2^3$ , while the bit weights for a "tens" digit would be  $10 \times 2^0$ ,  $10 \times 2^1$ ,  $10 \times 2^2$ , and  $10 \times 2^3$ .

#### 4.9 Frame rate

Frame rates are either an integer number of frames per second or an integer number divided by 1.001 per second.

## 5 Time Representation in 30 and 60 Frames-Per-Second Systems

### 5.1 Definitions of Real Time and NTSC Time

#### 5.1.1 Definition of real time

In a system operating at a frame rate of 30 frames per second, exactly one second of real time elapses during the duration of 30 frames. In a system operating at a frame rate of 60 frames per second, exactly one second of real time elapses during the duration of 60 frames.

#### 5.1.2 Definition of NTSC time<sup>2</sup>

In an NTSC television system operating at a frame rate of 30/1.001 frames per second (a field rate of 60/1.001 fields per second), one second of NTSC time elapses during the duration of 30 television frames. Because of the difference in scanning rates, the relationship between real time ( $t_{\text{REAL}}$ ) and NTSC time ( $t_{\text{NTSC}}$ ) is:

$$t_{\text{NTSC}} = 1.001 * t_{\text{REAL}},$$

Note: There are other television systems (such as some HDTV systems) which operate at 24/1.001, 30/1.001, or 60/1.001 frames per second. The term “NTSC time” is used to indicate its historical origins and to describe the common frame time base of all of these systems.

Note: The results of dividing the integer frame rates by 1.001 do not result in precise decimal numbers, for example, 30/1.001 is 29.970029970029... (to 12 decimals). This is commonly abbreviated as 29.97. In a similar manner, it is common to abbreviate 24/1.001 as 23.98, and 60/1.001 as 59.94. These abbreviations are used throughout this document. Sufficient precision is necessary in calculations to assure that rounding or truncation operations will not create errors in the end result. This is particularly important when calculating audio sample alignments or when long-term time keeping is required.

### 5.2 Time Address of a Frame

Each frame shall be identified by a unique and complete address consisting of an hour, minute, second, and frame number. For systems operating at 60 frames per second, each frame pair shall be identified by a unique and complete address consisting of an hour, minute, second, and frame number.

Note: Refer to SMPTE 258M for standard character data formats.

The hours, minutes, and seconds follow the ascending progression of a 24-hour clock beginning with 00 hours, 00 minutes, and 00 seconds to 23 hours, 59 minutes, and 59 seconds. The frames shall be numbered successively according to the counting mode (drop frame or non-drop frame) as described below.

Note: See § 12 for additional information regarding television systems which operate at 60 frames per second.

#### 5.2.1 Non-drop frame – Uncompensated mode

Frames shall be successively numbered 00 through 29, with no omissions.

#### 5.2.2 Drop frame – NTSC time compensated mode

Because the frame rate of an NTSC-time related 30 frames-per-second television signal is 30/1.001 frames per second ( $\approx 29.97$  Hz, which also is a field rate of 60/1.001 fields per second,  $\approx 59.94$  Hz), monotonically counting at 30 frames per second will yield a deviation of approximately +108 frames (+3.6 s) in one hour of elapsed time.

---

<sup>2</sup> This term is chosen to indicate its historical origins, not to be proscriptive.

To minimize the NTSC time deviation from real time, the first two frame numbers (00 and 01) shall be omitted from the count at the start of each minute except minutes 00, 10, 20, 30, 40, and 50.

Because the frame rate of a progressive NTSC-time related 60 frames-per-second television signal is actually 60/1.001 frames per second, and each time code count references a frame pair, the same counting mechanism may be applied as well. See § 12 for additional information on this subject.

Note: When drop-frame compensation is applied to an NTSC television time code, the total deviation accumulated after one hour is reduced to approximately  $-3.6$  ms. The total deviation accumulated over a 24-hour period is approximately  $-2.6$  frames ( $-86$  ms).

### 5.3 Color Frame Identification in NTSC Analog Composite Television Systems

If color frame identification in the time code is required, the even units of frame numbers shall identify color fields I and II, and the odd units of frame numbers shall identify color fields III and IV, as specified in SMPTE 170M.

Note: Even though a component system does not have a color sequence, the time code may carry color sequence information from an original video source so that recoding of a composite signal into a component signal and back can preserve the original color sequence relationship.

## 6 Time Representation in 25 and 50 Frames-Per-Second Systems

### 6.1 Definition of Real Time

In a system running at a frame rate of 25 frames per second, exactly one second of real time elapses during the duration of 25 frames. In a system running at a frame rate of 50 frames per second, exactly one second of real time elapses during the duration of 50 frames.

Note: In rare instances, such as standards conversion, some systems use an NTSC-time related timebase, resulting in a frame rate of 25/1.001 (24.9750...<sup>3</sup>).

### 6.2 Time Address of a Frame

Each frame shall be identified by a unique and complete address consisting of an hour, minute, second, and frame number. For systems operating at 50 frames per second, each frame pair shall be identified by a unique and complete address consisting of an hour, minute, second, and frame number.

The hours, minutes, and seconds follow the ascending progression of a 24-hour clock beginning with 00 hours, 00 minutes, and 00 seconds to 23 hours, 59 minutes, and 59 seconds. The frames (or frame pairs for 50 frames-per-second systems) shall be numbered successively 00 through 24.

There is no counting mode such as drop frame (which is applicable only to 30-frame counting) that is applicable to 25-frame counting.

Note: See § 12 for additional information regarding television systems which operate at frame rates of 50 frames per second.

### 6.3 Color Frame Identification in PAL Composite Television Systems

If identification of the eight-field color sequence in the time code is required, the time address shall bear a deterministic relationship with the eight-field color sequence (as specified in ITU-R BT.1700). This relationship can be expressed using either logical or arithmetic notations as given in § 6.3.1 and § 6.3.2, respectively.

---

<sup>3</sup> Please see the Note in § 5.1.2 regarding rounding errors.

Note: Even though a component system does not have a color sequence, the time code could carry color sequence information from an original video source so that recoding of a composite signal into a component signal and back can preserve the original color sequence relationship.

### 6.3.1 Logical relationship

Given that the frame and second numbers of the time address are expressed as BCD digit pairs, the value of the logical expression  $(A|B) \wedge C \wedge D \wedge E \wedge F$  shall be:

"1" for fields 1, 2, 3, and 4;

"0" for fields 5, 6, 7, and 8;

where:

A equals the value of the 1's bit of the frame number;  
 B equals the value of the 1's bit of the second number;  
 C equals the value of the 2's bit of the frame number;  
 D equals the value of the 10's bit of the frame number;  
 E equals the value of the 2's bit of the second number;  
 F equals the value of the 10's bit of the second number;  
 | represents the logical OR operation;  
 ^ represents the logical EXCLUSIVE OR operation.

### 6.3.2 Arithmetic relationship

The remainder of the quotient of the division  $(S + P) / 4$  shall be:

0 for fields 7 and 8;

1 for fields 1 and 2;

2 for fields 3 and 4;

3 for fields 5 and 6;

where:

S equals the decimal value of the seconds digits of the time address, and

P equals the decimal value of the frames digits of the time address.

## 7 Time Representation in 24 Frames-Per-Second Systems

### 7.1 Definitions of Real Time and NTSC Time

#### 7.1.1 Definition of real time

In a system running at a frame rate of 24 frames per second, exactly one second of real time elapses during the duration of 24 frames.

#### 7.1.2 Definition of NTSC time

In a NTSC-time related television signal operating at  $\square 24/1.001$  frames per second (approximately  $23.98^4$ ), straightforward counting at 24 frames per second will yield a deviation of approximately 86 frames (3.6 seconds) in one hour of elapsed time.

Where it is desired to maintain a correspondence with 30 frame per second systems the 30 non-drop frame count mode should be used. For additional details refer to Annex B.1.

---

<sup>4</sup> Please see the Note in § 5.1.2 regarding rounding errors.

## 7.2 Time Address of a Frame

Each frame shall be identified by a unique and complete address consisting of an hour, minute, second, and frame number. The hours, minutes, and seconds follow the ascending progression of a 24-hour clock beginning with 00 hours, 00 minutes, and 00 seconds to 23 hours, 59 minutes, and 59 seconds. The frames shall be numbered successively 00 through 23.

There is no counting mode such as drop frame (which is applicable only to 30-frame counting) that is applicable to 24-frame counting.

## 8 Structure of the Time Address and Control Bits

### 8.1 Numeric Code

The numeric code consists of sixteen groups, eight four-bit groups containing time address and flag bits, and eight four-bit binary groups for user-defined data and control codes.

### 8.2 Time Address

The basic structure of the time address is based upon the BCD system, using units and tens in digit pairs for hours, minutes, seconds, and frames. Some of the digits are limited to values that do not require all four bits to be significant. These bits shall be omitted from the time address and include the "80's" and "40's" of hours, "80's" of minutes, "80's" of seconds, and the "80's" and "40's" of frames. Thus the entire time address is coded into 26 bits.

### 8.3 Flag Bits

Six bits shall be reserved for the storage of flags which define the operational mode of the time and control code. A device which decodes a time and control code may utilize these flags to properly interpret the time address and binary group data.

#### 8.3.1 Drop frame flag

This flag shall be set to logical one when drop-frame compensation is being performed as specified in § 5.2.2. When the count is not drop-frame compensated, this flag bit shall be set to logical zero.

#### 8.3.2 Color frame flag (NTSC and PAL composite color systems)

If this flag is set to logical one it shall indicate that color frame identification has been applied to the time address as defined in § 5.3 or § 6.3. If this flag is set to logical zero then there is no implied relationship between the color frame sequence and the time address.

Note: Color frame identification may be forced by an original source of time and control code by halting the time address count until the color field to time code relationship is satisfied, after which the time address is incremented normally for each frame. As long as neither the time address counting sequence nor the color field sequence is changed, the relationship will remain satisfied.

#### 8.3.3 Binary group flags

Three flags provide eight unique combinations which signify the use of the binary groups (see § 8.4). Three combinations of these flags also specify that the time address count is referenced to a time-of-day clock reference (see § 8.5) and these flag combinations also identify subsets of the binary group applications.

Note: The term Binary Group Flags represents its historical origins, however these flags now also signal time address count parameters.

### 8.3.4 Modulation method specific flag

The remaining flag bit is reserved for use by each modulation method. This flag is defined in § 9.2.5 and § 10.2.4.

## 8.4 Use of the Binary Groups

The binary groups are intended for storage and transmission of data by the users. The format of the data contained in the binary groups is specified by the value of three binary group flag bits BGF2, BGF1, and BGF0. The following sections illustrate the assignments of the binary group flag states. The relevant documents cited in each subsection provide the definitions for the use of each Binary Group flag assignment. Table 1 summarizes the present assigned combinations.

Note: The binary groups are commonly referred to as "user bits".

**Table 1 – Binary group flag assignments**

BGF2	BGF1	BGF0	Time address reference	Binary group	Reference Section
0	0	0	Unspecified	Unspecified	§ 8.4.1
0	0	1	Unspecified	8-bit codes	§ 8.4.2
0	1	0	Clock time	Unspecified	§ 8.4.3, § 8.5
0	1	1	Reserved	Reserved	§ 8.4.4
1	0	0	Unspecified	Date and time zone	§ 8.4.5
1	0	1	Unspecified	Page/line	§ 8.4.6
1	1	0	Clock time	Date and time zone	§ 8.4.7, § 8.5
1	1	1	Clock time	Page/line	§8.4.8, § 8.5

Note: SMPTE RP 135, which specifies the use of binary groups for Motion Picture applications, specifies Binary Group flag combinations which are applicable only to the time code specified in RP136 for Motion Picture applications. The two time codes specified in SMPTE RP 136 are similar to the time code specified in this document, but have significant differences in their overall structure.

#### 8.4.1 Character set not specified and unspecified clock time (BGF2=0, BGF1=0, BGF0=0)

When used, this combination of binary group flags shall signify that the time address reference is undefined and that the binary groups contain an unspecified character set. The 32 bits within the eight binary groups may be assigned in any manner without restriction.

#### 8.4.2 Eight-bit character set and unspecified clock time (BGF2=0, BGF1=0, BGF0=1)

When used, this combination shall signify that the time address reference is undefined and that the binary groups contain an eight-bit character set conforming to ISO/IEC 646 or ISO/IEC 2022. If the seven-bit ISO codes are being used, they shall be converted to eight-bit codes by setting the eighth bit to 0.

Four ISO codes may be encoded in the binary groups, each occupying two binary groups. The first ISO code is contained in binary groups 7 and 8, with the least significant four bits in binary group 7 and the most significant four bits in binary group 8. The three remaining ISO codes are stored in binary groups 5/6, 3/4, and 1/2 accordingly.

#### 8.4.3 Character set not specified and clock time specified (BGF2=0, BGF1=1, BGF0=0)

When used, this combination shall specify that the time address is referenced to an external time-of-day clock and signifies an unspecified character set. The 32 bits within the eight binary groups may be assigned in any manner without restriction (see also § 8.5).

#### **8.4.4 Reserved binary group usage and reserved clock time (BGF2=0, BGF1=1, BGF0=1)**

This combination is reserved for future definition by SMPTE, and shall not be used.

#### **8.4.5 Date/time zone and unspecified clock time (BGF2=1, BGF1=0, BGF0=0)**

When used, this combination shall signify that the time address reference is undefined and that the binary groups contain date and time zone data encoded as described in SMPTE 309M.

#### **8.4.6 Page/line multiplex system and unspecified clock time (BGF2=1, BGF1=0, BGF0=1)**

When used, this combination shall signify that the time address reference is undefined and that the binary groups contain information formatted according to the page/line multiplex system as described in SMPTE 262M. This multiplex system defines a hierarchy that can be used to encode large amounts of data in the binary groups through the use of time multiplexing. Applications for this encoding scheme include control codes, text data, and production information.

#### **8.4.7 Date/time zone and clock time (BGF2=1, BGF1=1, BGF0=0)**

When used, this combination shall signify that the time address is referenced to an external time-of-day clock and shall signify date and time zone encoding as described in SMPTE 309M (see also § 8.5).

#### **8.4.8 Page/line multiplex system and clock time specified (BGF2=1, BGF1=1, BGF0=1)**

When used, this combination shall signify that the time address is referenced to an external time-of-day clock and shall signify the page/line multiplex system as described in SMPTE 262M. This multiplex system defines a hierarchy that can be used to encode large amounts of data in the binary groups through the use of time multiplexing. Applications for this encoding scheme include control codes, text data, and production information (also see § 8.5).

### **8.5 Clock Time Reference – Binary Group Flag Combinations**

Three flag combinations are used when the time address has been referenced to a time-of-day clock reference. These flag combinations also signify subsets of the available binary group applications (see § 8.4.3, § 8.4.7, and § 8.4.8). One of these combinations also signifies the encoding of the time zone and the date in the binary groups (see § 8.4.7).

Note: Additional information relating to time precision is included in Annex A.

## **9 Linear Time Code Application**

### **9.1 Codeword Format**

Each LTC codeword consists of 80 bits numbered 0 through 79. The bits are generated serially beginning with bit 0. Bit 79 of the codeword is followed by bit 0 of the next codeword. For systems operating at 30 Hz or below, each codeword is normally associated with one television frame. For systems operating above 30 Hz, each codeword is normally associated with a pair of television frames.

### **9.2 Codeword Data Content**

Each LTC codeword contains the time address, flag bits, binary groups, biphasic mark polarity correction bit, and a synchronization word.

#### **9.2.1 Time address**

The time address bits are defined in § 8.2. The lowest numbered bit of each group corresponds to the least significant bit of each BCD digit. The bit positions are listed in Table 2.

**Table 2 – LTC time address bit positions**

Bit	Definition
0 – 3	Units of frames
8 – 9	Tens of frames
16 – 19	Units of seconds
24 – 26	Tens of seconds
32 – 35	Units of minutes
40 – 42	Tens of minutes
48 – 51	Units of hours
56 – 57	Tens of hours

### 9.2.2 Flag bits

The drop frame, color frame, and binary group flag bits are defined in § 8.3. The bit positions are listed in table 3. Note that not all flag bits are used by all systems, as designated by the symbol "-". Unused flag bits shall be set to 0 by original sources and ignored by receiving equipment.

Note: Users are advised that some legacy devices may set unused flag bits to other values.

**Table 3– LTC flag bit positions**

30-frame Bit	25-frame Bit	24-frame Bit	Definition
10	- [10]	- [10]	Drop frame flag
11	11	- [11]	Color frame flag
27	59	27	Polarity correction
43	27	43	Binary group flag BGF0
58	58	58	Binary group flag BGF1
59	43	59	Binary group flag BGF2

### 9.2.3 Biphase mark polarity correction

This flag bit is specific to the LTC modulation method described in § 9.3. The position of this flag is listed in Table 3.

Because of the nature of the modulation method, the polarity of the first clock transition of the first bit of the synchronization word may differ from codeword to codeword depending on the number of logical zeros in the data.

Applications which switch between two sources of time and control code may require the polarity of the two sources to be stable during the synchronization word. If polarity stabilization of the sync word is required, the biphase mark polarity correction bit shall be put in a state so that every 80-bit codeword will contain an even number of logical zeros.

This requirement is summarized as follows:

When polarity correction of the codeword is required and the number of logical zeros in bit positions 0 through 63 (exclusive of the polarity correction bit itself) is odd, then the polarity correction bit shall be set to logical one, otherwise the polarity correction bit shall be set to logical zero.

### 9.2.4 Binary groups

Eight four-bit binary groups are defined in § 8.3. The lowest numbered bit of each group corresponds to the least significant bit of that group. The positions of the bits are listed in Table 4.

**Table 4 – LTC binary group bit positions**

Bit	Definition
4 to 7	First binary group
12 to 15	Second binary group
20 to 23	Third binary group
28 to 31	Fourth binary group
36 to 39	Fifth binary group
44 to 47	Sixth binary group
52 to 55	Seventh binary group
60 to 63	Eighth binary group

**9.2.5 Synchronization word**

The synchronization word is a static combination of bits which can be used by receiving equipment to accurately identify the bit position of the serial code. The LTC synchronization word is unique in that the same combination cannot be generated by any combination of valid data values in the remainder of the code.

Bits 65 to 78 form a unique pattern that is symmetrical about the center of the synchronization word, allowing detection in either direction. Bits 64 and 79 are complements of each other, allowing a receiver to determine the direction of the code.

**Table 5 – LTC synchronization word bit positions and values**

Sync word Bit position	Sync word bit value
64	0
65	0
66	1
67	1
68	1
69	1
70	1
71	1
72	1
73	1
74	1
75	1
76	1
77	1
78	0
79	1

**9.3 Modulation Method**

The LTC codeword is biphase mark encoded according to the following coding rules (see Figure 1):

- a) a transition occurs at each bit cell boundary, regardless of the value of the bit;
- b) a logical one is represented by an additional transition occurring at the bit cell midpoint;
- c) a logical zero is represented by having no additional transitions within the bit cell.

The biphase mark encoded signal has no DC component, is amplitude and polarity insensitive, and includes transitions at every bit cell boundary from which the clock may be extracted.

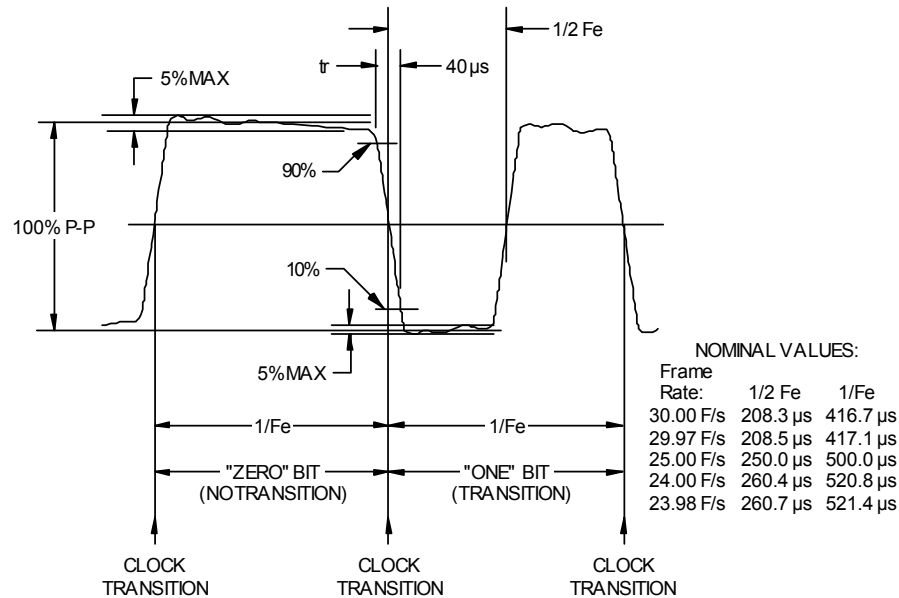

Figure 1 – Linear time code source output waveform

#### 9.4 Bit Rate

The bits shall be evenly spaced throughout the codeword period, and shall fully occupy the codeword period which is one frame or two television fields. Consequently, the nominal rate,  $F_e$ , at which the bits are generated, shall be:

$$F_e = 80 * F_f$$

where:

$F_f$  is the frame rate of the LTC time code.

If an original source generates an LTC signal referenced to a television signal, the bit clock shall be phase locked to the television signal. In such case, each LTC codeword is normally associated with one television frame. (Note: See § 12 for the exception). However, if an original source generates an LTC signal without a reference, the frequency tolerance shall be  $\pm 100$  ppm.

#### 9.5 Timing of the Codeword Relative to a Television Signal

The timing reference datum for LTC shall be the half-amplitude point of the first transition of bit 0 of the 80-bit LTC codeword.

For analog television systems the video reference datum is the start of vertical sync. For digital television systems, the video reference datum is the start of the video frame. For 525/59.94 systems this is the start of line 4 and for all other systems this is the start of line 1.

Note: SMPTE RP 168, Appendix A defines the timing relationship between the different video formats with common time bases.

The first transition of bit 0 of the codeword shall occur at the reference datum of the video frame with which it is associated. The tolerance shall be  $-32 / +160$  μs.

For television systems operating above 30 frames per second, the video reference datum is the start of line 1 of the first frame of the frame pair to which the LTC is associated. The individual frames should be identified

by their timing relative to the LTC with the first frame of the pair aligned with LTC bits 0 through 39 and the second frame of the pair aligned with LTC bits 40 through 79. Figure 5 shows an example of the relationship between the resulting LTC and the video signal.

Examples of the alignment of LTC to some 30, 29.97, 25, 24 and 23.98 frames-per-second television systems are shown in Figure 2, Figure 3, and Figure 4.

Note: Since LTC may be recorded on a different track or stored in a separate area from the video signal on a storage medium, the phase relation between the reproduced LTC and the reproduced video signal may vary during the range of full system operation, while keeping the basic function of video frame identification. Such a video system may regenerate the LTC during playback. See § 4.7 discussion of "source" versus "original source."

This standard specifies the tolerance for the datum alignment at the output of an Original LTC Source. A receiver shall as a minimum accept the tolerances of a source time code.

Note: Users are advised that in operational systems the datum alignment is subject to deviation.

## **9.6 Linear Time Code Interface Electrical and Mechanical Characteristics**

All measurements shall be made at the LTC interface while driving a resistive load of 1 k $\Omega$  and the source device is running at normal play speed.

### **9.6.1 Rise/fall time**

The rise and fall times of the transitions of the time code pulse train shall be 40  $\mu$ s  $\pm$  10  $\mu$ s, measured between the 10 % and 90 % amplitude points on the waveform.

### **9.6.2 Amplitude distortion**

Any combination of overshoot, undershoot, and tilt shall be limited to 5 % of the peak-to-peak amplitude of the signal waveform.

### **9.6.3 Timing of the transitions**

The time between clock transitions shall not vary by more than 1.0 % of the average clock period measured over at least the time of one frame. The "one" transition shall occur midway between the two clock transitions within 0.5 % of one clock period. Measurement of these timings shall be made at half-amplitude points on the waveform.

### **9.6.4 Interface connector** (Informative)

The preferred connector for double-ended or balanced outputs is a 3-pin XLR (MALE) and for inputs a 3-pin XLR (FEMALE). Pin 1 is chassis ground, pins 2 and 3 carry the double-ended or balanced signals. The preferred connector for single-ended or unbalanced outputs or inputs is a BNC (FEMALE).

### **9.6.5 Output impedance**

The output impedance of a single-ended, balanced or unbalanced source shall be no greater than 50  $\Omega$ . The output impedance of a double-ended output shall be no greater than 25  $\Omega$  for each output side.

### **9.6.6 Output amplitude** (Informative)

The preferred output amplitude is between 1 V and 2 V peak-to-peak. The allowable range of amplitudes is 0.5 V to 4.5 V peak-to-peak.



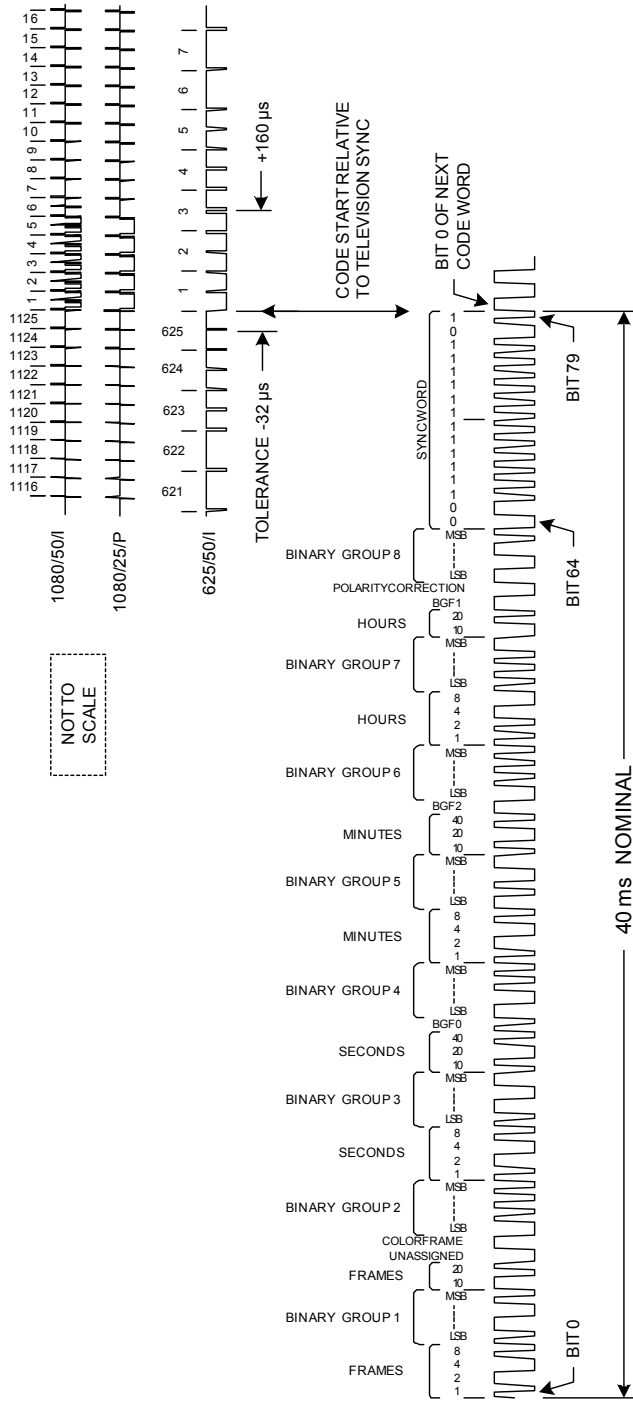

Figure 3 – 25-frame linear time code example



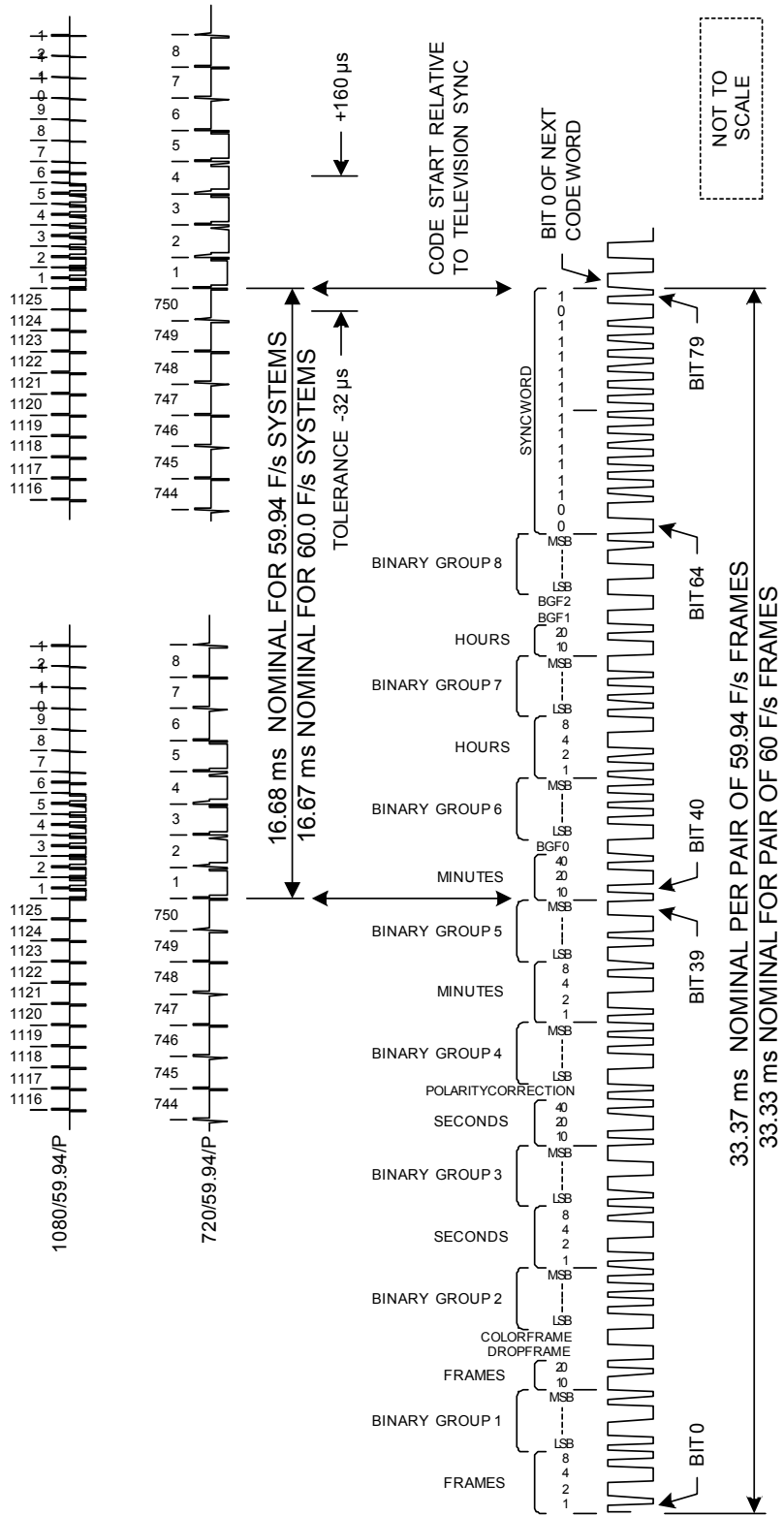

Figure 5 – Linear time code relationship to 59.94-frame progressive video example

## 10 Vertical Interval Application — Analog Television Systems

Note: Digital television systems are encouraged to use ATC for this application. Alternatively, D-VITC may be used.

### 10.1 Codeword Format

Each codeword shall consist of 90 bits numbered 0 through 89, organized as nine groups of ten bits. Each ten-bit group starts with a synchronization bit pair, which is a logical one bit followed by a logical zero bit. The synchronization bit pair is followed by eight data bits.

The first eight groups contain the sixty-four time and control code data bits, the ninth contains a cyclic redundancy check (CRC) code used to detect errors in the VITC codeword.

The boundaries of the codeword are defined as the leading edge of the first bit (bit 0) and the trailing edge of the last bit (bit 89). Since bit 0 is the first synchronization bit of the codeword, it shall always have the value of logical one. Thus, there will always be a rising transition at the leading edge of bit 0 to signal the start of the word.

### 10.2 Codeword Data Content

Each VITC codeword consists of a time address, flag bits, binary groups, field mark flag, CRC code, and synchronization bits. Refer to Figure 6 and Figure 7 for examples of the VITC signal.

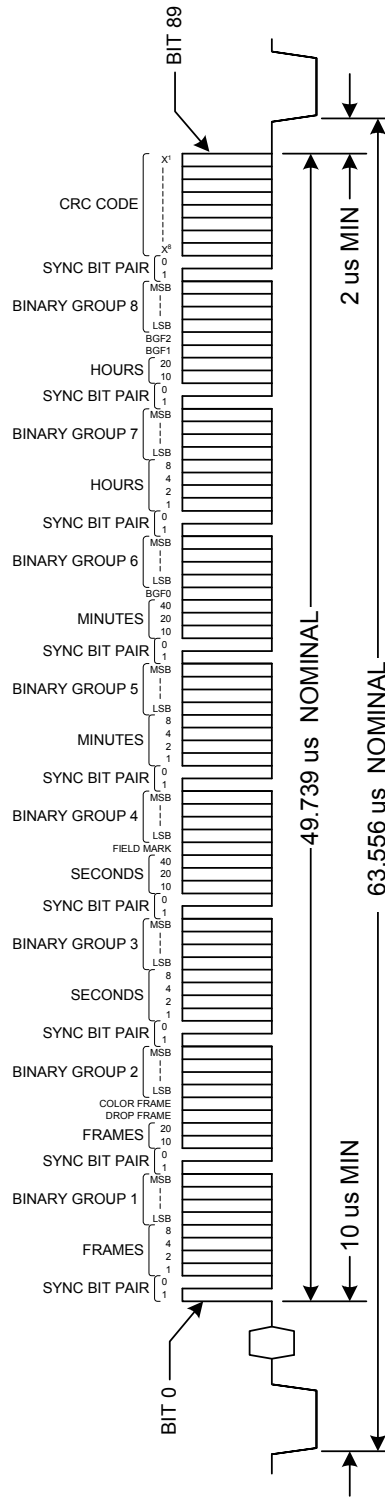

Figure 6 – 525/59.94 vertical interval time code address bit assignment and timing

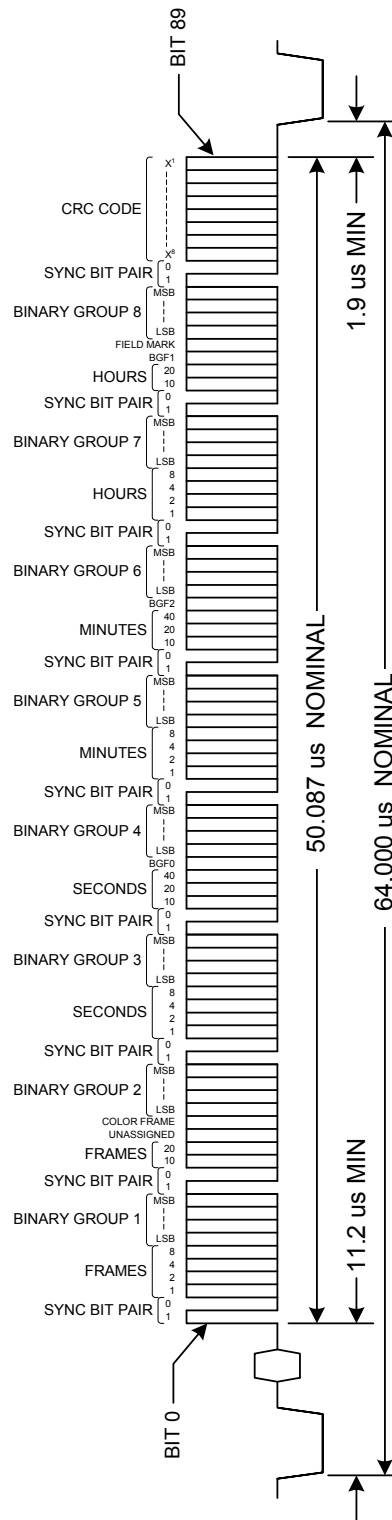

Figure 7 – 625/50 vertical interval time code address bit assignment and timing

**10.2.1 Time address**

The time address bits of the frame are defined in § 8.2. The lowest numbered bit of each group corresponds to the least significant bit of each BCD digit. The positions of these bits are listed in Table 6.

**Table 6 – VITC time address bit positions**

Bit	Definition
2 – 5	Units of frames
12 – 13	Tens of frames
22 – 25	Units of seconds
32 – 34	Tens of seconds
42 – 45	Units of minutes
52 – 54	Tens of minutes
62 – 65	Units of hours
72 – 73	Tens of hours

**10.2.2 Flag bits**

The drop frame, color frame, and binary group flag bits are defined in § 8.3. The positions of these flags are listed in Table 7. Note that not all flag bits are used by all systems, as designated by the symbol “-”. Unused flag bits shall be set to logical zero by Original Sources, and ignored by receiving equipment.

**Table 7 – VITC flag bit positions**

30-frame Bit	25-frame Bit	24-Frame Bit	Definition
14	- [14]	- [14]	Drop frame flag
15	15	- [15]	Color frame flag
35	75	35	Field identification flag
55	35	55	Binary group flag BGF0
74	74	74	Binary group flag BGF1
75	55	75	Binary group flag BGF2

**10.2.3 Binary groups**

Eight four-bit binary groups are defined in § 8.4. The lowest numbered bit of each group corresponds to the least significant bit of that group. The positions of these bits are listed in Table 8.

**Table 8 – VITC binary group bit positions**

Bit	Definition
6 – 9	First binary group
16 – 19	Second binary group
26 – 29	Third binary group
36 – 39	Fourth binary group
46 – 49	Fifth binary group
56 – 59	Sixth binary group
66 – 69	Seventh binary group
76 – 79	Eighth binary group

## 10.2.4 Field identification flag

The position of this flag shall be as listed in Table 7.

### 10.2.4.1 NTSC composite television system

Field identification shall be recorded as follows: A logical zero shall represent monochrome field 1 or color field I or III. A logical one shall represent monochrome field 2 or color field II or IV. Color fields I through IV are defined in SMPTE 170M.

### 10.2.4.2 PAL composite television system

Field identification shall be recorded as follows: A logical zero shall represent color fields 1, 3, 5, and 7. A logical one shall represent color fields 2, 4, 6, and 8. Color fields 1 through 8 are defined in the annex to ITU-R BT.1700-1.

### 10.2.4.3 Analog component television system

Field identification shall be recorded as follows: A logical zero shall represent field 1. A logical one shall represent field 2.

## 10.2.5 Synchronization bits

A synchronization bit pair consisting of a logical one followed by a logical zero is inserted preceding every eight data bits. Bits 0, 10, 20, 30, 40, 50, 60, 70, and 80 are coded as logical one; bits 1, 11, 21, 31, 41, 51, 61, 71, and 81 are encoded as logical zero.

## 10.2.6 Cyclic redundancy check code

Eight bits, 82 through 89, are encoded with a cyclic redundancy check (CRC) code to provide for error detection by cyclic redundancy.

The generating polynomial of the CRC code,  $G(X)$ , is defined as  $G(X) = X^8 + 1$  with an initial condition of 0.

The generating polynomial shall be applied to all bits from 0 to 81 inclusive. The remainder is then encoded in bits 82 through 89 as shown in Table 9.

Applying the generating polynomial to the received data, bits 0 through 89 inclusive, shall result in a remainder of 0 when no error exists.

**Table 9 – CRC bit positions**

Bit	CRC code bit
82	$X^8$
83	$X^7$
84	$X^6$
85	$X^5$
86	$X^4$
87	$X^3$
88	$X^2$
89	$X^1$

### 10.3 Modulation Method

The VITC codeword is NRZ modulated and inserted as a single codeword within the non-blanked interval of a selected television line in the vertical interval (see Figure 8). Logic level to signal level specifications are listed in § 10.8.1.

Since an NRZ code has no self-clocking reference, the signal shall be sampled at periodic intervals based on known bit cell timing. The sample period can be adjusted at any available 1-0 or 0-1 transition. Because of the insertion of fixed-value synchronization bits, a transition is guaranteed to occur at least every ten bits.

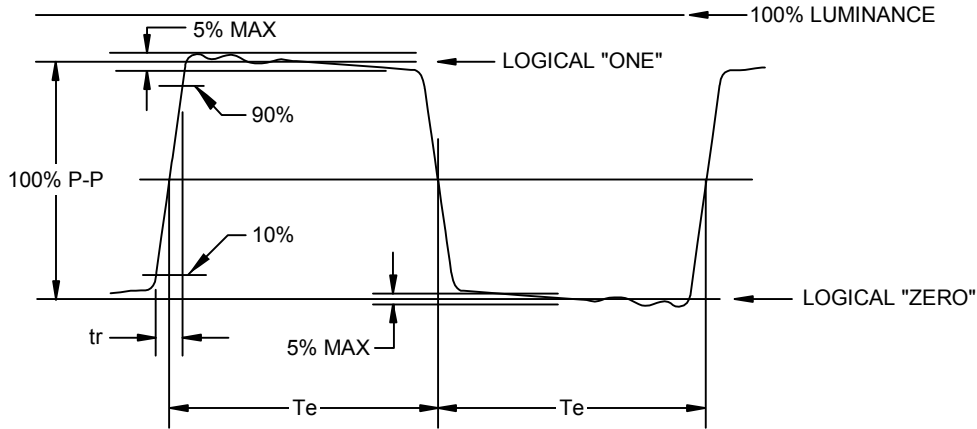

Figure 8 –Vertical interval time code waveform

### 10.4 Bit Timing

Each bit of the codeword shall have a uniform period,  $T_e$ , related to the horizontal line frequency,  $F_h$ , as expressed below:

$$T_e = \left( \frac{1}{(115 * F_h)} \right) \pm 2\%$$

Note – Previous definitions of the bit timing for 525/59.94 and 625/50 television systems are different from that given here, but do lie within the tolerance range given.

### 10.5 Timing of the Codeword Relative to the Television Signal

#### 10.5.1 525/59.94 television system

The half-amplitude point of bit 0 shall occur no earlier than 10.0  $\mu$ s following the half-amplitude point of the leading edge of the line synchronizing pulse. The half-amplitude point of the trailing edge of bit 89 (logical one) shall occur no later than 2.1  $\mu$ s before the half-amplitude point of the leading edge of the following line synchronizing pulse.

#### 10.5.2 625/50 television system

The half-amplitude point of bit 0 shall occur no earlier than 11.2  $\mu$ s following the half-amplitude point of the leading edge of the line synchronizing pulse. The half-amplitude point of the trailing edge of bit 89 (logical one) shall occur no later than 1.9  $\mu$ s before the half-amplitude point of the leading edge of the following line synchronizing pulse.

## 10.6 Location of the VITC Codeword in the Vertical Interval

The VITC codeword shall be inserted on the same line (or lines) in each field for a given analog SDTV signal. Line numbers shown in parentheses correspond to the equivalent line in field two.

### 10.6.1 525/59.94 television system

Insertion of the address code shall not be earlier than line 10(273) or later than line 20(283). The preferred placement of the VITC codeword is on line 14(277) and optionally on line 16(279).

If it is necessary to preserve compatibility with older equipment, VITC should appear on two nonconsecutive lines in each field.

In such case the preferred lines are 14(277) and 16(279) except:

- lines 12(275) and 14(277) in type C recorders with sync heads;
- lines 16(279) and 18(281) in type C recorders without sync heads.

### 10.6.2 625/50 television system

Insertion of the address code shall not be earlier than line 6(319) or later than line 22(335). The preferred placement of the VITC codeword is on television lines 19(332) and 21(334).

### 10.6.3 Component television systems

In analog component systems, the VITC codeword shall be carried in the Y (also known as luma or luminance) video channel.

## 10.7 Redundancy

The address code may be inserted in multiple lines of the vertical interval, provided all lines contain the same time address, drop frame, and color frame data.

Redundancy of the binary group data is dependent on the binary group flags and the requirements of the encoding system which their values indicate.

## 10.8 Vertical Interval Time Code Waveform Characteristics

This subsection specifies the waveform characteristics of the VITC signal (refer to Figure 8.)

### 10.8.1 Logic level

The tolerance ranges specified for logical one and logical zero states are listed in Table 10.

**Table 10 – VITC logic level ranges**

Television system	Logical one	Logical zero
525/59.94	70--90 IRE <sup>5</sup>	0 – 10 IRE
625/50	500--600 mV	0 – 25 mV

Note: For analog component systems, the logic levels apply to the Y video channel.

<sup>5</sup> See Annex B of SMPTE 170M for a definition of IRE units.

### 10.8.2 Rise/fall time

The rise and fall times of the code shall be  $200 \text{ ns} \pm 50 \text{ ns}$  for 525/60 and 625/50 television systems. These measurements shall be made between 10 % and 90 % amplitude points on the waveform.

### 10.8.3 Amplitude distortion

Amplitude distortions, such as overshoot, undershoot, and tilt, shall be limited to 5 % of the peak-to-peak amplitude of the code waveform.

## 11 Relationship Between LTC and VITC

Note: The relationship between LTC and VITC specified here is primarily addressed to analog television systems, however it may also apply to SDTV digital systems employing D-VITC. The relationship may also apply to digital systems employing VITC data carried in ATC.

### 11.1 Time Address Data

Because of the relative timing of the two time code modulation methods, direct interchange of time address bits is not possible in real time. In order to generate a linear time code from a vertical interval time code, or vice versa, the time address of one frame is incremented by one unit and used as the time address of the next frame. Drop frame and color frame flag bits (if applicable) are maintained.

This method will produce a one-to-one correspondence between the time address and flag bits of the linear time code and the vertical interval time code as long as the counting sequence is continuous and ascending. Discontinuities will propagate to the output time code after one frame of delay.

### 11.2 Binary Group Data

When transferring binary group data, a one-frame update, similar to that used in time address data transfer, may be applied if the nature of the binary group data format lends itself to being predictable. If this is not the case, then no update shall be applied to the data and the transfer will result in a one-frame delay.

The guideline for transferring binary group data between linear and vertical interval time codes shall be as follows:

#### 11.2.1 Transferring VITC binary group data to LTC binary group data

The binary group data and flag bits from the first VITC codeword contained in the vertical interval shall be transferred to the corresponding bits in the linear time code of the next frame.

#### 11.2.2 Transferring LTC binary group data to VITC binary group data

The binary group data and flag bits from the linear time code shall be transferred to the corresponding bits in the vertical interval time code of the next frame.

If the binary group data format, as identified by the binary group flag bits, supports line or field independence, then the binary group data and flags of the remaining lines in the vertical interval code for that frame shall be set to logical zero. If the binary group data format is redundant, then the redundant lines in the frame shall contain identical data.

### 11.3 VITC and LTC Codeword Comparison

Table 11 summarizes the correspondence between the VITC and LTC codewords for 60-, 50-, 30-, 25-, and 24-frame systems.

Table 11 – Summation of VITC and LTC codeword bit definitions

VITC bit no.	Value (weight)	Common assignment	LTC bit no.	30-frame/60-field 60-frame	25-frame/50-field 50-frame	24-frame
0	1	VITC SYNC BITS				
1	0					
2	(1)	FRAME UNITS	0			
3	(2)		1			
4	(4)		2			
5	(8)		3			
6	(LSB)	FIRST BINARY GROUP	4			
7			5			
8			6			
9	(MSB)		7			
10	1	VITC SYNC BITS				
11	0					
12	(10)	FRAME TENS	8			
13	(20)		9			
14	FLAG	FLAG	10	DROP FRAME FLAG	SET TO ZERO	SET TO ZERO
15	FLAG	FLAG	11	COLOR FRAME FLAG	COLOR FRAME FLAG	SET TO ZERO
16	(LSB)	SECOND BINARY GROUP	12			
17			13			
18			14			
19	(MSB)		15			
20	1	VITC SYNC BITS				
21	0					
22	(1)	SECOND UNITS	16			
23	(2)		17			
24	(4)		18			
25	(8)		19			
26	(LSB)	THIRD BINARY GROUP	20			
27			21			
28			22			
29	(MSB)		23			
30	1	VITC SYNC BITS				
31	0					
32	(10)	SECOND TENS	24			
33	(20)		25			
34	(40)		26			
35	FLAG	FLAG	27	FIELD BIT / LTC POLARITY	BINARY GROUP FLAG 0	FIELD BIT / LTC POLARITY
36	(LSB)	FOURTH BINARY GROUP	28			
37			29			
38			30			
39	(MSB)		31			
40	1	VITC SYNC BITS				
41	0					
42	(1)	MINUTE UNITS	32			
43	(2)		33			
44	(4)		34			
45	(8)		35			
46	(LSB)	FIFTH BINARY GROUP	36			
47			37			
48			38			
49	(MSB)		39			

VITC bit no.	Value (weight)	Common assignment	LTC bit no.	30-frame/60-field 60-frame	25-frame/50-field 50-frame	24-frame
50	1	VITC SYNC BITS				
51	0					
52	(10)	MINUTE TENS	40			
53	(20)		41			
54	(40)		42			
55	FLAG	FLAG	43	BINARY GROUP FLAG 0	BINARY GROUP FLAG 2	BINARY GROUP FLAG 0
56	(LSB)	SIXTH BINARY GROUP	44			
57			45			
58			46			
59	(MSB)		47			
60	1	VITC SYNC BITS				
61	0					
62	(1)	HOUR UNITS	48			
63	(2)		49			
64	(4)		50			
65	(8)		51			
66	(LSB)	SEVENTH BINARY GROUP	52			
67			53			
68			54			
69	(MSB)		55			
70	1	VITC SYNC BITS				
71	0					
72	(10)	HOUR TENS	56			
73	(20)		57			
74	FLAG	FLAG	58	BINARY GROUP FLAG 1	BINARY GROUP FLAG 1	BINARY GROUP FLAG 1
75	FLAG	FLAG	59	BINARY GROUP FLAG 2	FIELD BIT / LTC POLARITY	BINARY GROUP FLAG 2
76	(LSB)	EIGHTH BINARY GROUP	60			
77			61			
78			62			
79	(MSB)		63			
80	1	VITC SYNC BITS				
81	0					
82-89		VITC CRC CODE				
		LTC SYNC WORD	64-79			

## 12 Progressive Systems with Frame Rater Greater than 30 Frames Per Second

### 12.1 Time Address of a Frame Pair in 50 and 60 Frames-Per-Second Progressive Systems

Since the frame rate of 50 and 60 frames-per-second progressive systems exceeds the frame count capacity of the time address, the count shall be constrained to increment only every other frame (as shown in Figure 9). This results in an edit resolution of two frames<sup>6</sup>.

Where the time code is conveyed as VITC data (for example as in ATC), the field mark flag should be used to identify each frame of the frame pair. The preferred implementation is to set the field mark flag of the VITC data to zero for the first frame of a pair and to one for the second frame of a pair.

Where the time code is modulated as LTC the codeword shall be aligned to the television signal as specified by § 9.5.

<sup>6</sup> With extensive external processing of the time code data it is possible to achieve one frame resolution and still meet all requirements of this standard.

**12.2 Implementation Guidelines** (Informative)

Users of this standard are advised that various implementations of the field mark flag contained in the VITC data and carried as ATC exist. Users are further cautioned that ATC packets are not carried in protected HANC or VANC areas of the serial interface, thus they may be overwritten.

In time code compliant with previous versions of this standard, time code values for time representation in progressive systems cannot be distinguished from time code values in interlaced systems. Such distinction must be determined by other parameters such as the line scanning structure at the interface. Where the time code values are used in data systems, other methods must be provided to ensure that this distinction can be determined.

Users are advised to verify which of these methods is implemented in their equipment, so that interoperability problems can be avoided.

To be compliant with the current version of this standard all new implementations that convey the timecode as VITC data carried in ATC should implement the use of the field mark flag.

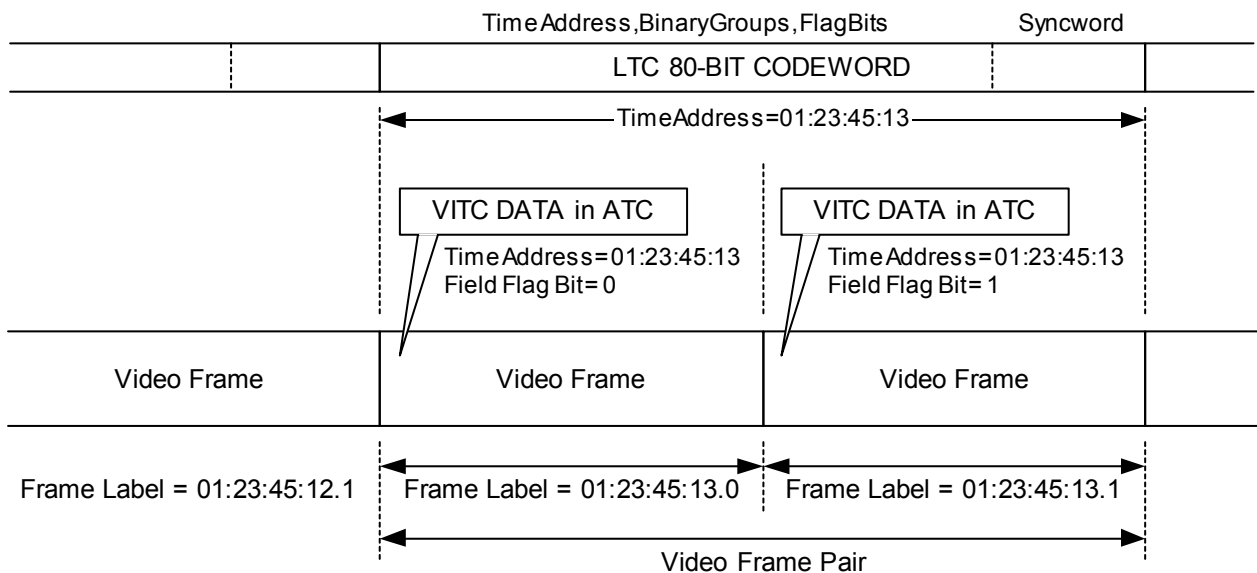

**Figure 9 – Example of frame labeling for 50 and 60 frames-per-second progressive systems**

## **Annex A (Informative) Explanatory Notes**

### **A.1 Time Precision**

Some time code applications use the time code to convey clock time and must be maintained in synchronization with time-of-day clock time. The precision of the clock time in the time code can be subject to variances due to the video phase relative to midnight rollover, the use of color field identification, cyclic drift associated with drop frame compensation, systematic drift associated with non-integer frame rates, the reference video frequency accuracy, and the precision of the clock reference. It is the responsibility of the system implementers to take appropriate measures to ensure satisfactory system operation.

SMPTE 309M provides a method of signaling the degree of time precision that is intended. It also provides for indicating the date and time zone to which the time applies.

### **A.2 Leap Second Corrections**

Because of small differences between atomic time (UTC) and time based on the rotational speed of the earth (UTC1), periodic adjustments to atomic time are made in increments of 1 second. These adjustments, when required, are made at the end of June 30, or December 31, universal time, so that UTC never deviates by more than 0.9 second. The last minute of the day on which an adjustment is made has 61 seconds or 59 seconds. It could happen that leap seconds would need to be removed (negative leap seconds); however, all leap seconds so far have been positive. Since many television facilities operate with their facility time code generator tied to an external time reference, such as GPS, leap second adjustments can affect broadcast operations. In such cases, the binary group flags (see § 8.4 and 8.5) should signal "clock time."

The occurrence of a positive leap second time correction results in a second of time being added. It might not be possible to create or display a time address label with the value of 60 seconds to identify uniquely this second due to the design of existing compliant SMPTE time code devices. For uniformity in adding a leap second, it is suggested that at the end of the hour, the last second with a value of 59 seconds might be repeated.

For 625/50 systems that also implement color field identification, the occurrence of a leap second adjustment can result in a time shift of one or three frames depending on the method of adjusting time to identify the color frame sequence. Users are advised that this can change the intended time precision of the system.

Users are advised that some devices which use time code primarily as a label might not generate or correctly recognize 59-second or 61-second minutes, and might treat such as labeling errors when they are encountered. Notwithstanding this limitation, such devices are fully compliant with this standard.

### **A.3 Frames and Time Code**

Fundamentally, a given value of time code labels a moment of time. This document uses the specifications of traditional raster-scan video formats to obtain the duration of a unit of time to which a time code sample is attached. This is called a frame. Users are advised that certain time code values can be skipped (or never associated with a frame of video). This is called the "drop frame" mode of time code counting.

For example, in a 525-line ("NTSC") signal running at its native frame rate (30/1.001 frames per second), each video frame's duration is 1.001/30 seconds (approximately 33.3667 ms). This is then taken to define the duration of the frame each specific time code sample is applied to. Similarly, in a 625-line signal running at a standard frame rate (25 frames per second), a video frame's duration is 1/25 second (40 ms), and this defines the time code frame duration.

Time code can be used in systems which have no associated video format, such as audio streams, synchronization signals, or object based digital formats. In such systems, the duration of the frame must be specified in terms to match a frame's duration as if it were defined by reference to some video format .

For example, in an audio stream running at a true 48000 samples per second ("48 kHz sampling"), the time code Frame's duration can be defined several ways, depending on system requirements. If the Frame is defined as  $48000 / (25 / 1)$  to match a standard frame rate 625-line signal, the time code sample labels 1920 audio samples. If the Frame is defined as  $48000 / (30000 / 1001)$  to match a standard frame rate 525-line signal, time code sample labels 1601.6 audio samples, or 8008 samples in 5 Frames. If the Frame is defined as  $48000 / (30 / 1)$ , to match a non-standard frame rate 525-line signal, the time code labels 1600 audio samples. Other combinations are possible, but might not represent "real world" implementations.

System designers must use appropriate choices for the time code frame duration and take account of its implications, such as the non-terminating decimal representation of rational numbers, to assure consistent behavior.

**Annex B (Informative)**

**Converting Time Codes when Converting Video from 24 Frames-Per-Second Television Systems**

When rate converting 24 Fps (frames per second) video to 25 or 30 Fps video by periodically replicating video fields, the conversion hardware inserts extra fields of some of the images to create a pull-down cadence of the picture content on the converted output. In addition the incoming time code must be converted from a nominal 24 Fps to 25 Fps or 30 Fps rate. This method is valid as well for conversions between non-integer frame rate numbers. A different method for conversion between “integer number” frame rates to “non-integer number” frame rates can be used and is beyond the scope of this document.

**B.1 Conversion of 24/1.001 (23.98) Fps Video to 30/1.001 (29.97) Fps Video**

In order to deterministically move between the nominal 24 and 30 frames-per-second formats it is recommended that the video frames of the 24 Fps high definition material with the time code frame number zero be converted to an A frame as shown in Figure B.1. These frames are called the A frame candidate frames. SMPTE 318M also recommends that these A frames are aligned with the field identified by the Field 1 pulse of the 10 field sequence as shown in Figure B.1. It follows then that subsequent 24 Fps high definition frame numbers that are evenly divisible by 4 will also become A frames. As specified in § 7 of this standard, the 30 non-drop frame count mode is strongly recommended to be used for the time code of the converted material. It is recommended that the A frame candidate zero frame be numbered as the zero frame on the converted video, resulting in subsequent A frames of the converted video having time code frame numbers that are evenly divisible by 5.

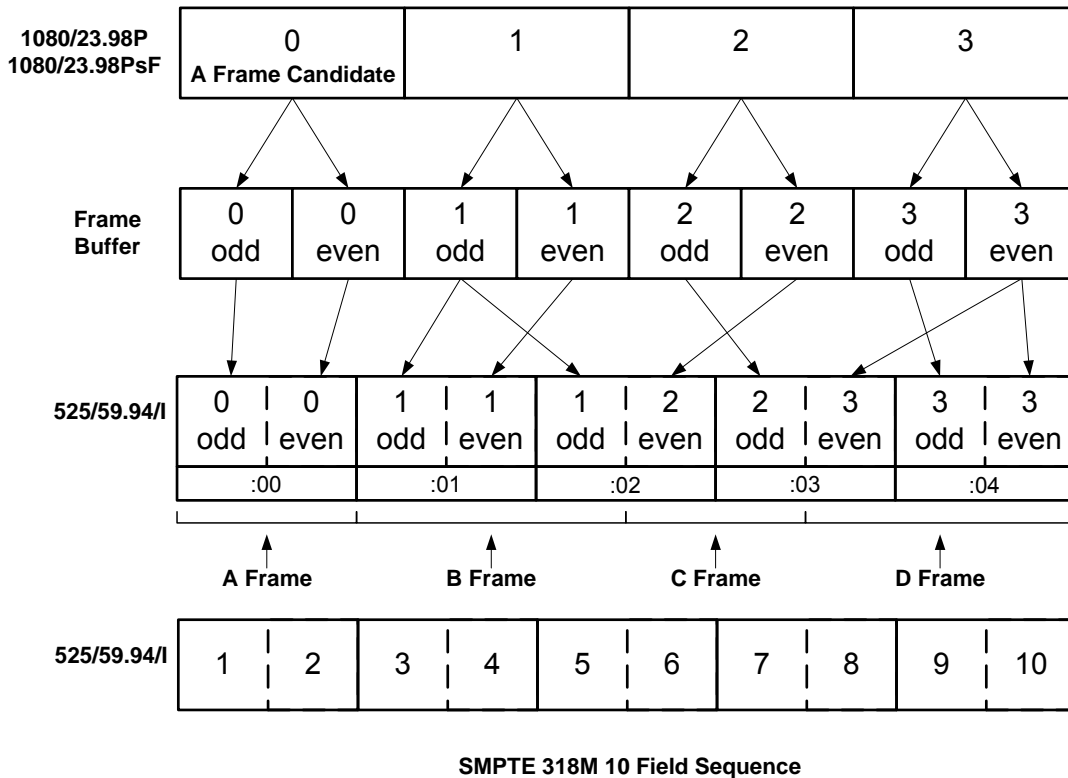

**Figure B.1 – Example of conversion of 23.98 Fps video to 525/59.94/I**

As there are delays through the conversion hardware it may not be possible to align the vertical sync at the start of an A frame with the vertical sync at the start of an A frame candidate frame, but the vertical sync at the beginning of the A frame (line 4 for 525 systems) should be aligned with the vertical sync at the beginning of one of the input frames (line 1) as shown in SMPTE RP 168.

### B.2 Conversion of 24 Fps Video to 25 Fps Video

For specific editorial applications it may be desirable to perform an 11(2):3 pull-down conversion between systems operating at 24 and 25 frames per second. Due to the visibility of temporal artifacts this process is not recommended for release material.

In order to deterministically move between the 24 and 25 frames-per-second formats it is recommended that the video frames of the 24 Fps material with the time code frame number zero be converted to the first A frame or the 24:25 frame pull-down sequence as shown in Figure B.2. These frames are called the A1 frame candidate frames. It follows then each that subsequent 24 Fps frame number zero will also become an A frame at the start of the 24:25 pull-down cycle. The converted A1 frame should be numbered as the zero frame of the time code second.

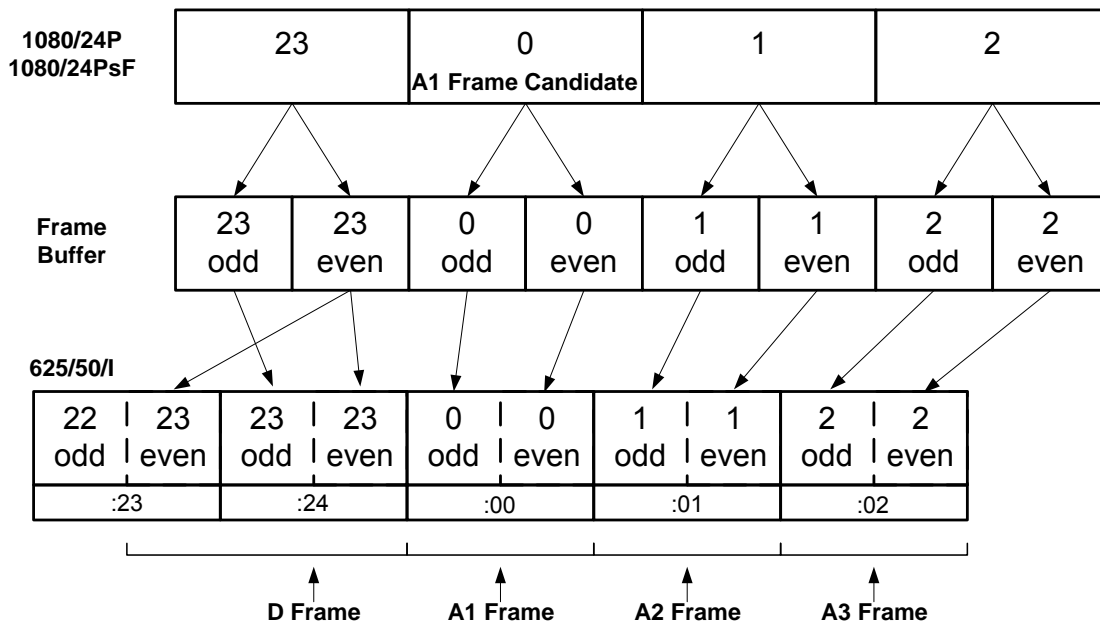

Figure B.2 – Example of Conversion from 24 Fps High Definition video to 625/50/I

As there are delays through the conversion hardware it might not be possible to align the vertical sync at the start of an A1 frame with the vertical sync at the start of an A1 candidate frame, but the vertical sync at the beginning of the A1 frame (line 1 for 625 systems) can be aligned with the vertical sync at the beginning of one of the input frames (line 1).

## **Annex C (Informative)**

### **Bibliography**

ARIB STD B4, Version 2,0, Time Code Conveyed by Ancillary Data Packets for 1125/60 Television Systems (available in the Japanese language only)

EBU Technical Standard N12-1999, Time-and-Control Codes for Television Recording

IEC 60169-8 with Amendment 1 and 2<sup>7</sup>, "R.F. Coaxial Connectors with Inner Diameter of Outer Conductor 6,5mm (0,256 in) with Bayonet Lock – Characteristics Impedance 50 Ohms (Type BNC)"

IEC 60461:2001, Time and Control Code for Video Tape Recorders

ITU-R BT.470-6 (1998) Annex 1, Conventional Television Systems (Note: Obsoleted by ITU-R BT.1700-1, Characteristics of Composite Video Signals for Conventional Analogue Television Systems)

ITU-R BT.1366 (1998-R2003) Transmission of Time Code and Control Code in the Ancillary Data Space of a Digital Television Stream According to Recommendations ITU-R BT.656, ITU-R BT.799 and ITU-R BT.1120

SMPTE 12M-2-2008, Television — Transmission of Time Code in the Ancillary Data Space

SMPTE 125M-1995, Television — Component Video Signal 4:2:2 — Bit-Parallel Digital Interface

SMPTE 240M-1999, Television — 1125-Line High-Definition Production Systems — Signal Parameters

SMPTE 258M-2004, Television – Transfer of Edit Decision Lists

SMPTE 260M-1999, Television — 1125/60 High-Definition Production System — Digital Representation and Bit-Parallel Interface

SMPTE 266M-2002, Television — 4:2:2 Digital Component Systems — Digital Vertical Interval Time Code

SMPTE 274M-2008, Television — 1920 x 1080 Image Sample Structure, Digital Representation and Digital Timing Reference Sequences for Multiple Picture Rates

SMPTE 292-2008, 1 Gb/s Signal / Data Serial Interface

SMPTE 293M-2003, Television — 720 x 483 Active Line at 59.94-Hz Progressive Scan Production — Digital Representation

SMPTE 296M-2001, Television — 1280 x 720 Progressive Image Sample Structure — Analog and Digital Representation and Analog Interface

SMPTE 318M-1999, Television and Audio — Synchronization of 59.94- or 50-Hz Related Video and Audio Systems in Analog and Digital Areas — Reference Signals

SMPTE RP135-2004, Use of Binary User Groups in Motion-Picture Time and Control Codes

SMPTE RP 136-2004, Time and Control Codes for 24, 25 or 30 Frame-Per-Second Motion-Picture Systems

---

<sup>7</sup> Please note that the title of this reference may be misleading. This reference actually defines both the 50  $\Omega$  and the 75  $\Omega$  BNC connectors. While this standard specifies use of only the 50  $\Omega$  connector, most other SMPTE standards specify use of only the 75  $\Omega$  connector.

SMPTE RP 169-1995, Television, Audio and Film Time and Control Code — Auxiliary Time Address Data in Binary Groups — Dialect Specification of Directory Index Locations

SMPTE RP 179-2002, Dialect Specification of Page-Line Directory Index for Television, Audio and Film Time and Control Code for Video-Assisted Film Editing.

SMPTE EG 40-2002, Conversion of Time Values Between SMPTE 12M Time Code, MPEG-2 PCR Time Base and Absolute Time

**Annex D (Informative)**  
**Time Code System "Roadmap"**

