

SMPTE STANDARD

12 Gb/s Signal/Data Serial Interface — Electrical



Table of Contents	Page
Foreword.....	2
Intellectual Property.....	2
Introduction.....	2
1 Scope.....	3
2 Conformance Notation	3
3 Normative References	3
4 Source Data	4
4.1 Sync-Bit Insertion.....	6
4.2 Channel Coding and Serialization	8
5 Coaxial Cable Interface.....	8
5.1 Generator Signal Levels and Specifications.....	8
5.2 Receiver Signal Levels and Specifications.....	9
5.3 Return Loss	9
6 Connector and Cable Types	10
6.1 BNC Connectors.....	10
6.2 Cables.....	10
Annex A Bibliography (Informative).....	11
Annex B Channel Coding (Informative).....	12
Annex C Pot-Hole Pathological and the Sync-Bit Insertion Process (Informative)	13

Foreword

SMPTE (the Society of Motion Picture and Television Engineers) is an internationally-recognized standards developing organization. Headquartered and incorporated in the United States of America, SMPTE has members in over 80 countries on six continents. SMPTE's Engineering Documents, including Standards, Recommended Practices, and Engineering Guidelines, are prepared by SMPTE's Technology Committees. Participation in these Committees is open to all with a bona fide interest in their work. SMPTE cooperates closely with other standards-developing organizations, including ISO, IEC and ITU.

SMPTE Engineering Documents are drafted in accordance with the rules given in its Standards Operation Manual.

SMPTE ST 2082-1 was prepared by Technology Committee 32NF.

Intellectual Property

At the time of publication no notice had been received by SMPTE claiming patent rights essential to the implementation of this Standard. However, attention is drawn to the possibility that some of the elements of this document may be the subject of patent rights. SMPTE shall not be held responsible for identifying any or all such patent rights.

Introduction

This section is entirely informative and does not form an integral part of this Engineering Document.

SMPTE ST 2082-1 defines a bit-serial data interface for the transport of 12 Gb/s [nominal] component digital signals or packetized data. The mapping of various source image formats to the bit-serial data structure defined here in this document are described in additional SMPTE ST 2082 document parts.

SMPTE ST 2082-0 contains an informative roadmap for the 12 Gb/s Signal/Data Serial Interfaces.

End users are cautioned that they should work with Serial Digital Interface equipment vendors to ensure the electrical and mechanical capabilities of cables and connectors — whether existing or new — in support of this interface meet their requirements.

1 Scope

This standard describes the electrical and physical characteristics of a 12G-SDI coaxial cable interface suitable for applications where the signal loss does not exceed an amount specified by the receiver manufacturer. Typical loss amounts would be in the range of up to 40 dB at one-half the clock frequency.

2 Conformance Notation

Normative text is text that describes elements of the design that are indispensable or contains the conformance language keywords: "shall", "should", or "may". Informative text is text that is potentially helpful to the user, but not indispensable, and can be removed, changed, or added editorially without affecting interoperability. Informative text does not contain any conformance keywords.

All text in this document is, by default, normative, except: the Introduction, any section explicitly labeled as "Informative" or individual paragraphs that start with "Note:"

The keywords "shall" and "shall not" indicate requirements strictly to be followed in order to conform to the document and from which no deviation is permitted.

The keywords, "should" and "should not" indicate that, among several possibilities, one is recommended as particularly suitable, without mentioning or excluding others; or that a certain course of action is preferred but not necessarily required; or that (in the negative form) a certain possibility or course of action is deprecated but not prohibited.

The keywords "may" and "need not" indicate courses of action permissible within the limits of the document.

The keyword "reserved" indicates a provision that is not defined at this time, shall not be used, and may be defined in the future. The keyword "forbidden" indicates "reserved" and in addition indicates that the provision will never be defined in the future.

A conformant implementation according to this document is one that includes all mandatory provisions ("shall") and, if implemented, all recommended provisions ("should") as described. A conformant implementation need not implement optional provisions ("may") and need not implement them as described.

Unless otherwise specified, the order of precedence of the types of normative information in this document shall be as follows: Normative prose shall be the authoritative definition; Tables shall be next; followed by formal languages; then figures; and then any other language forms.

3 Normative References

The following standards contain provisions that, through reference in this text, constitute provisions of this standard. At the time of publication, the editions indicated were valid. All standards are subject to revision, and parties to agreements based on this standard are encouraged to investigate the possibility of applying the most recent edition of the standards indicated below.

SMPTE ST 2082-10:2015, 2160-line and 1080-line Source Image and Ancillary Data Mapping for 12G-SDI

SMPTE RP 184:2004, Specification of Jitter in Bit Serial Digital Systems

IEC 61169-8 (2007-2), Radio-Frequency Connectors — Part 8: Sectional Specification — R.F. Coaxial Connectors with Inner Diameter of Outer Conductor 6,5 mm (0,256 in) with Bayonet Lock — Characteristic

Impedance 50 Ω (Type BNC), Annex A (Normative) Information for Interface Dimensions of 75 Ω Characteristic Impedance Connector with Unspecified Reflection Factor^{1,2}

IEC 61169-29 (2005-6), Radio-Frequency Connectors — Part 29: Sectional Specification — Miniature Radio Frequency Coaxial Connectors Model Screw, Snap-on, Push-pull or Quick-lock, Slide-in (Rack and Panel Applications) — Characteristic Impedance 50 Ω (Type 1,0/2,3) – 50 Ω and 75 Ω Applications²

4 Source Data

For this interface, the source data shall be the 12G-SDI 10-bit Multiplex as defined for example in SMPTE ST 2082-10, of the form illustrated in the diagram of Figure 1 and Figure 2, having an interface frequency of 1188 MHz or 1188/1.001 MHz.

Note:

Figure 1 shows the Type 1 10-bit multiplex resulting from mapping modes in which each data stream has a single instance of TRS words, Line Numbers, CRC Words, etc.

Figure 2 shows the Type 2 10-bit multiplex resulting from mapping modes in which each data stream has two instances of TRS words, Line Numbers, CRC Words, etc. A type 2 multiplex is the result of SMPTE ST 292-1 mapping of each sub image. It is generated for 4:2:2 10-bit formats with frame rates of 30fps or less.

¹ Please note that the title of this normative reference could be misleading. This standard requires the use of the 75-ohm connector defined in Annex A of this reference.

² Please note that this reference is required ONLY to provide mechanical dimensions of 75 ohm connectors.

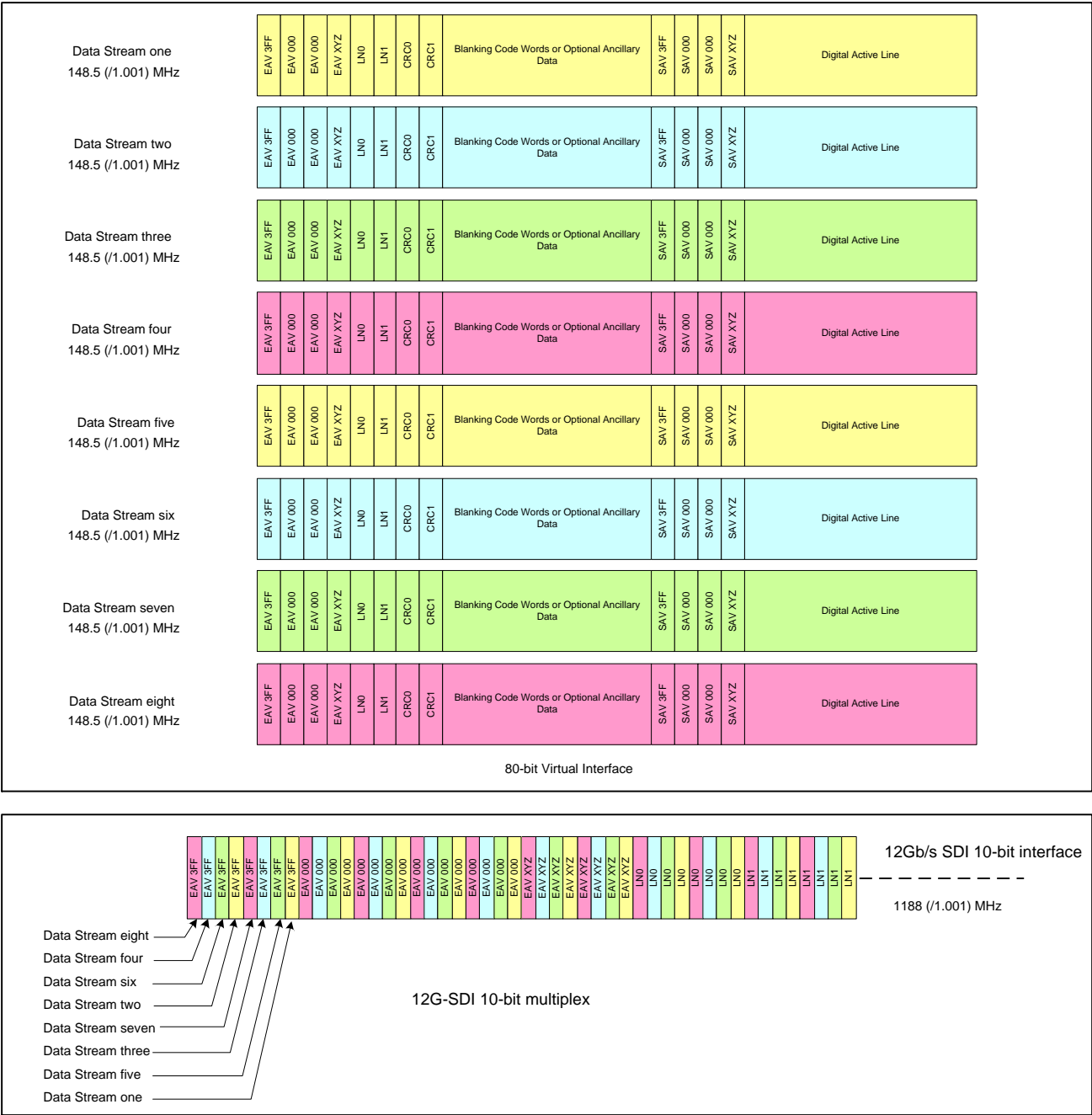

Figure 1 – 12G-SDI 10-bit Multiplex – Type 1

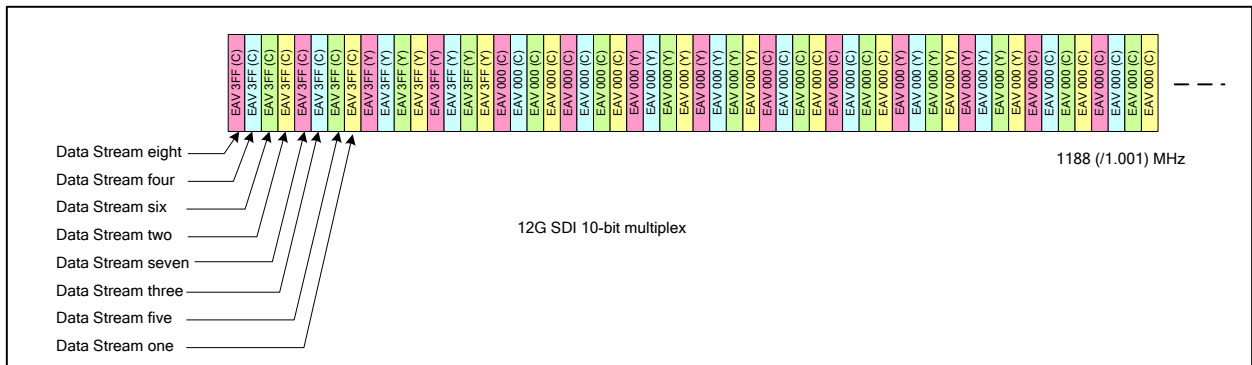
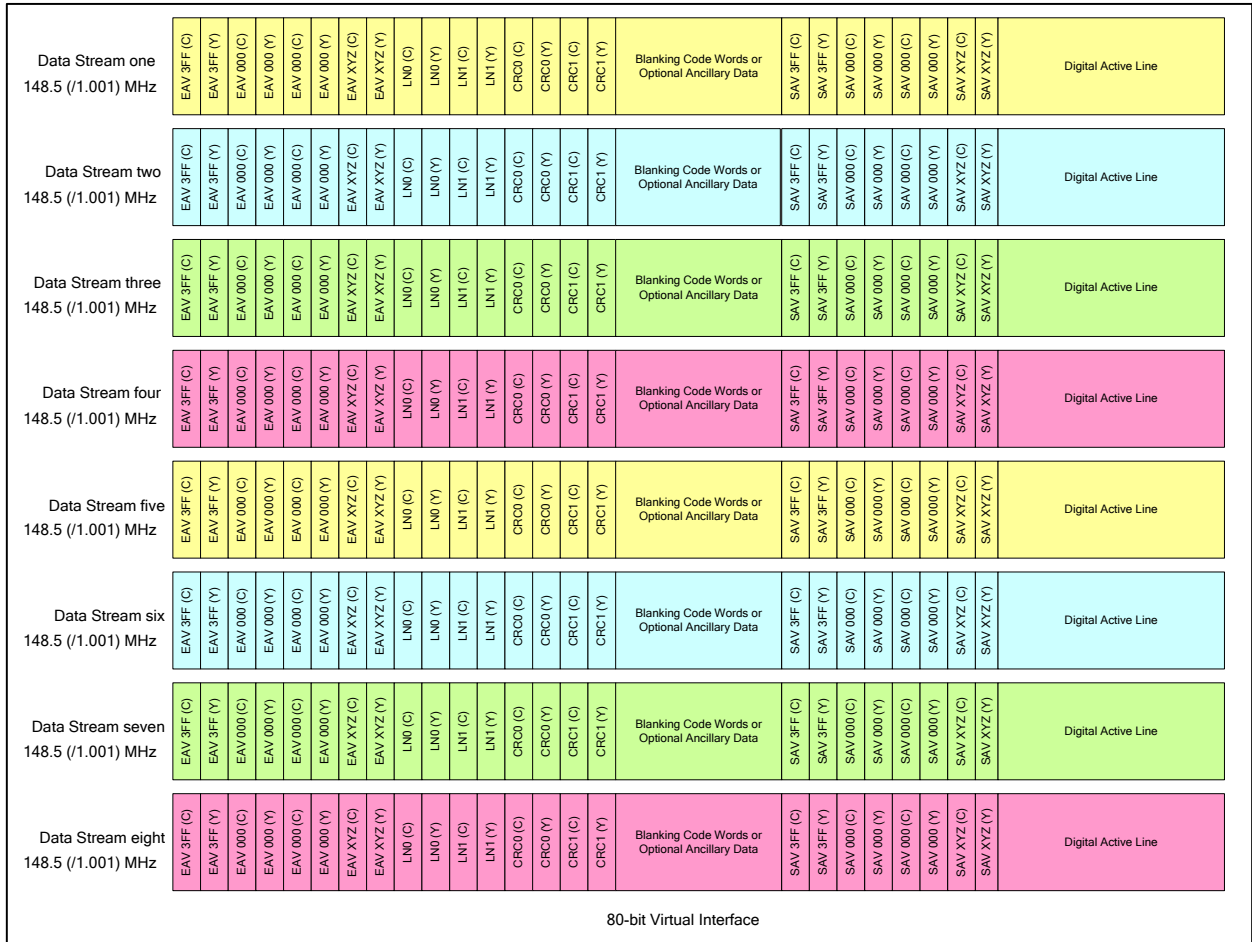

Figure 2 – 12G SDI 10-bit Multiplex- Type 2

4.1 Sync-Bit Insertion

To prevent long runs of zeros and ones occurring in the serial bit stream, the 10-bit parallel interface data stream shall be modified such that the two Least Significant Bits (LSB's), of repeated 3FF or 000 code words shall be replaced by the sync-bit values of 10b for 000h words and 01b for 3FFh words, excluding the 3FFh 000h 000h sequence as illustrated in the diagram of Figure 3.

To ensure synchronization and word alignment can be reliably achieved in the receiver, this 3FFh 000h 000h sequence shall be retained without modification as shown in Figure 3.

This Sync-bit insertion process shall be reversed in the receiver restoring the original 3FFh and 000h data patterns.

Note:

Repeating patterns of 3FF or 000h in the 10-bit parallel interface can result in a long run of zeros feeding the scrambling polynomial. This condition can result in the generation of the “Pot Hole Pathological” condition as described in the paper “Pathological Check Codes and the SMPTE Scrambler in the HD Age” published in the October 2011 edition of the SMPTE Motion Imaging Journal.

A run length of up to 160 “1’s” and up to 339 “0’s” can be produced as described in informative Annex C for the Type 2 multiplex, and 80 “1’s” and up to 179 “0’s” can be produced for the Type 1 multiplex.

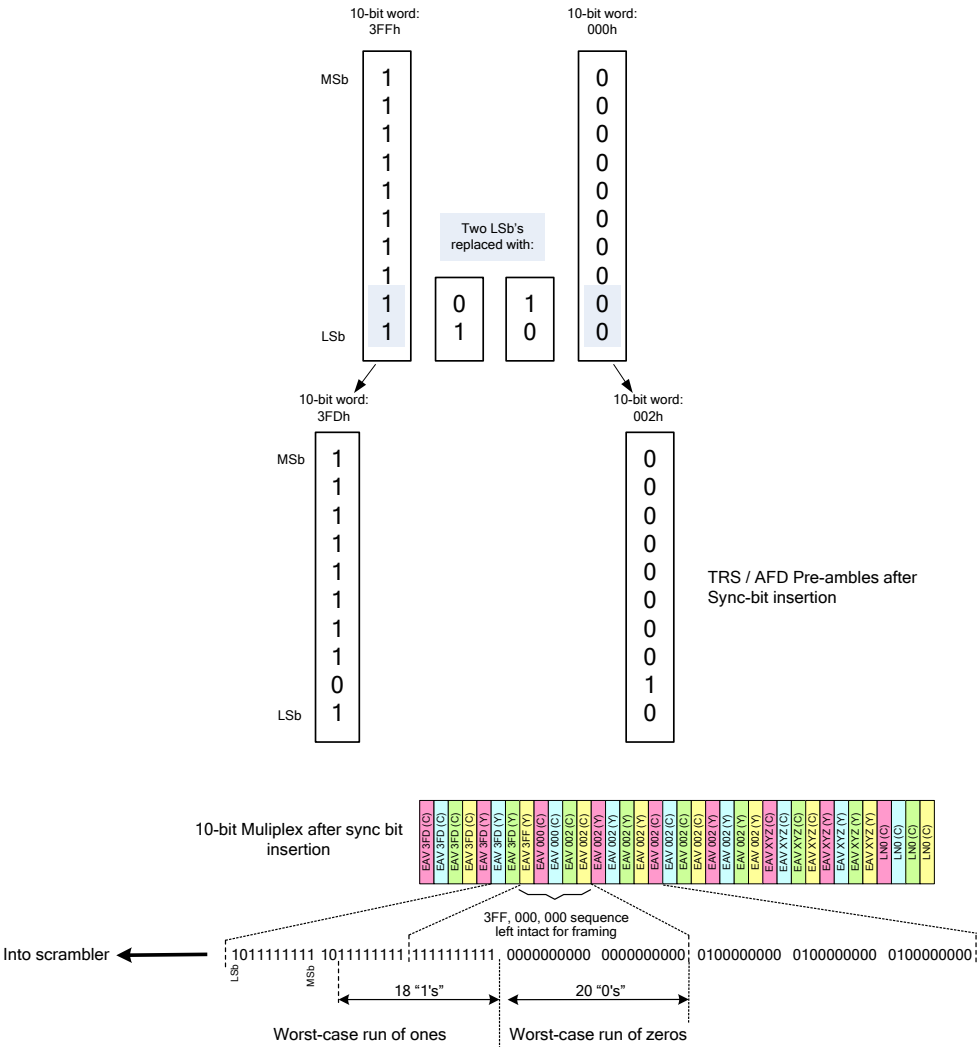

Figure 3 – Sync-bit Insertion process

4.2 Channel Coding and Serialization

Multiplexed data shall be serialized with the LSB (Least Significant Bit) of each data word transmitted first at a serial data rate of 11.88 Gb/s or 11.88/1.001 Gb/s.

The channel coding scheme shall be scrambled NRZI (non-return to zero inverted), See Annex C.

The generator polynomial for the scrambled NRZ shall be $G_1(X) = X^9 + X^4 + 1$. Polarity-free scrambled NRZI sequence data shall be produced by the generator polynomial $G_2(X) = X + 1$. The input signal to the scrambler shall be positive logic, where the highest voltage represents data 1 and the lowest voltage represents data 0.

5 Coaxial Cable Interface

5.1 Generator Signal Levels and Specifications

These specifications are defined for measurement of the serial output of a source derived from a parallel domain signal.

The output of the generator (source signal transmitter) shall be measured across a 75-ohm resistive load connected through a 1 meter coaxial cable and 75 ohm BNC connectors meeting the requirements defined in Section 6.2. Figure 4 depicts the measurement dimensions for amplitude, rise-time and overshoot.

The generator shall have an unbalanced output circuit with a source impedance of 75 ohms and shall meet the return loss requirements defined in Table 2.

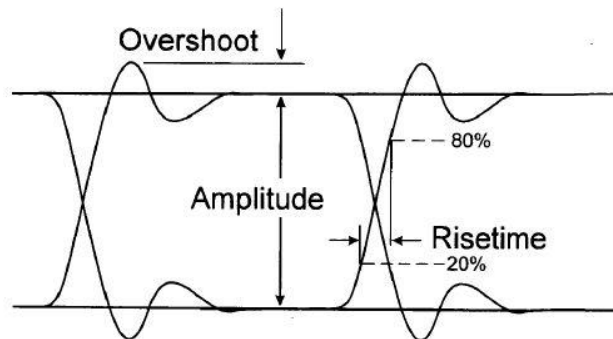

Figure 4 – Waveform measurement Dimensions

The peak-to-peak signal amplitude shall be $800 \text{ mV} \pm 10\%$.

The dc offset, as defined by the mid-amplitude point of the signal, shall be nominally $0.0 \text{ V} \pm 0.5 \text{ V}$.

The rise and fall times, determined between the 20% and 80% amplitude points shall be no greater than 45 ps and shall not differ by more than 18 ps.

Overshoot of the rising and falling edges of the waveform shall not exceed 10% of the amplitude.

Output amplitude excursions due to signals with a significant dc component occurring for a horizontal line (pathological stress signal) shall not exceed 50 mV above or below the average peak-to-peak signal envelope.

The jitter in the timing of the transitions of the data signal shall be measured in accordance with SMPTE RP 184. Measurement parameters are defined in SMPTE RP 184 and shall have the values shown in Table 1 for compliance with this standard.

Table 1 – Jitter Specifications

Parameter	Value	Description
f1	10 Hz	Timing Jitter lower band edge (Low Frequency Specification Limit)
f3	100 kHz	Alignment Jitter lower band edge
f4	> 1/10 th the clock rate (>1188 MHz)	Upper band edge
A1	2 UI (168 psec)	Timing jitter
A2	0.3 UI (28 psec)	Alignment jitter (UI = unit interval. 1 UI = 84 psec). Note 1
Test Signal	Color bar test signal	Note 2
Notes: 1 This should be considered an absolute maximum requirement. An alignment jitter specification of 0.2 UI or better is strongly recommended 2 Color bars are chosen as a non-stressing test signal for jitter measurements. Use of a stressing signal with long runs of zeros could give misleading results. 3 See SMPTE RP 184 for definition of terms		

5.2 Receiver Signal Levels and Specifications

The receiver of the serial interface signal shall present an impedance of 75 ohms and shall meet the return loss requirements defined in Table 2.

Receivers operating with input cable losses in the range of up to 40 dB at one-half the clock frequency are typical; however, receivers designed to work with greater or lesser signal attenuation are acceptable.

5.3 Return Loss

The generator and receiver unbalanced circuit shall have a return loss that complies with the diagram of Figure 5 in accordance with the parameters enumerated in Table 2.

**Figure 5 – Return loss**

Table 2 – Return Loss parameters

Parameter	Value	Description
F0	5 MHz	Return loss lower band edge
F1	1.485 GHz	Return loss transition lower band edge
F2	3 GHz	Return loss mid band edge
F3	6 GHz	Return loss mid band upper edge
F4	12 GHz	Return loss upper band edge
B0	-15 dB	Return loss f0 to f1
B1	-10 dB	Return loss f1 to f2
B2	- 7 dB	Return loss f2 to f3
B3	- 4 dB	Return loss f3 to f4

6 Connector and Cable Types

6.1 BNC Connectors

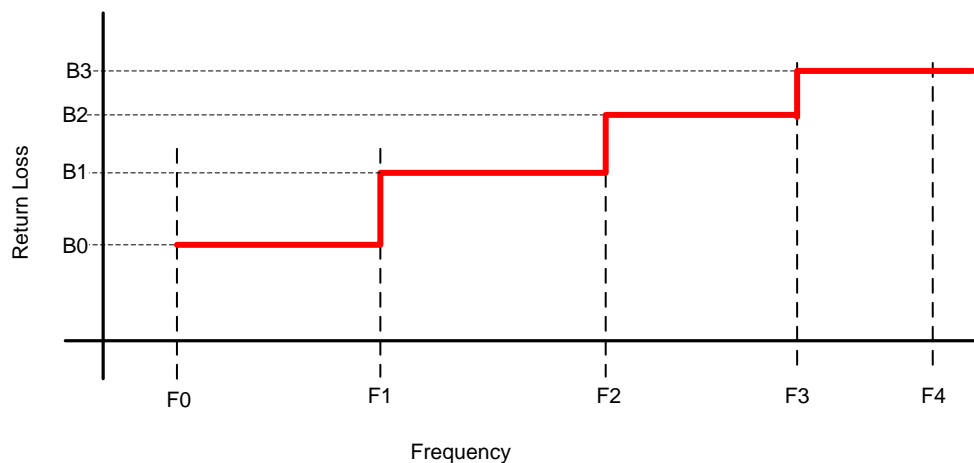
75-ohm BNC connectors that are usable at frequencies >12.0 GHz — based on a return loss at 12.0 GHz that is better than the parameters defined in Table 2 and an insertion loss (frequency response) that is lower than the typical cable loss identified in Section 6.2 — shall be used on equipment and installations that are compliant with this standard.

The mechanical characteristics of the preferred connector shall conform to the 75-ohm BNC as defined in IEC 61169-8, Annex A.

Other application-specific connector types may also be used so long as they meet the electrical requirements in this standard. Manufacturers are encouraged to indicate in publications which connector type is being used.

Examples of application-specific connector types include but are not limited to the 1,0/2,3 series RF connectors with mechanical dimensions as defined in IEC 61169-29 (2005-6) Radio-Frequency Connectors — Part 29: Miniature Radio Frequency Coaxial Connectors.

Section 8 of IEC 61169-8 provides additional suggested electrical parameters for connectors compliant with this standard.

Note: IEC 61169-8 and IEC 61169-29 are required only for interface (mechanical), dimensions of 75 Ω characteristic impedance connectors. Electrical specification for connectors compliant with this standard are as defined in this section.

6.2 Cables

75-ohm video coax cable that is specified for operation at frequencies >12.0 GHz shall be used in installations that are compliant with this standard. It is necessary for the frequency response of the coaxial cable loss, in decibels, to be approximately proportional to $1/\sqrt{f}$ from 1 MHz to the clock frequency of the signal being transmitted to ensure correct operation of automatic cable equalizers over moderate to maximum cable lengths.

Return loss of the correctly terminated transmission line shall be better than the parameters defined in Table 2.

Annex A Bibliography (Informative)

SMPTE EG 34:2004, Pathological Conditions in Serial Digital Video Systems

SMPTE RP 157:2012, Key and Alpha Signals

SMPTE RP 198:1998, Bit-Serial Digital Checkfield for Use in High-Definition Interfaces

SMPTE ST 292-1:2012, 1.5Gb/s Signal/Data Interface

SMPTE 2082-0:2015, 12G-SDI Bit-Serial Interfaces — Roadmap for the SMPTE 2082 Document Suite

Pathological Check Codes and the SMPTE Scrambler in the HD Age: SMPTE Motion Imaging Journal
October 2011.

Annex B Channel Coding (Informative)

When scrambled NRZI channel coding is applied to certain video signals (informally called pathological signals), repeated long strings of 19 or 20 zeros can occur during the period of one horizontal television line. A stressing test signal is defined in SMPTE RP 198 that will help in evaluating channel performance.

Possible generator polynomial implementations are given in Figures B.1 and B.2.

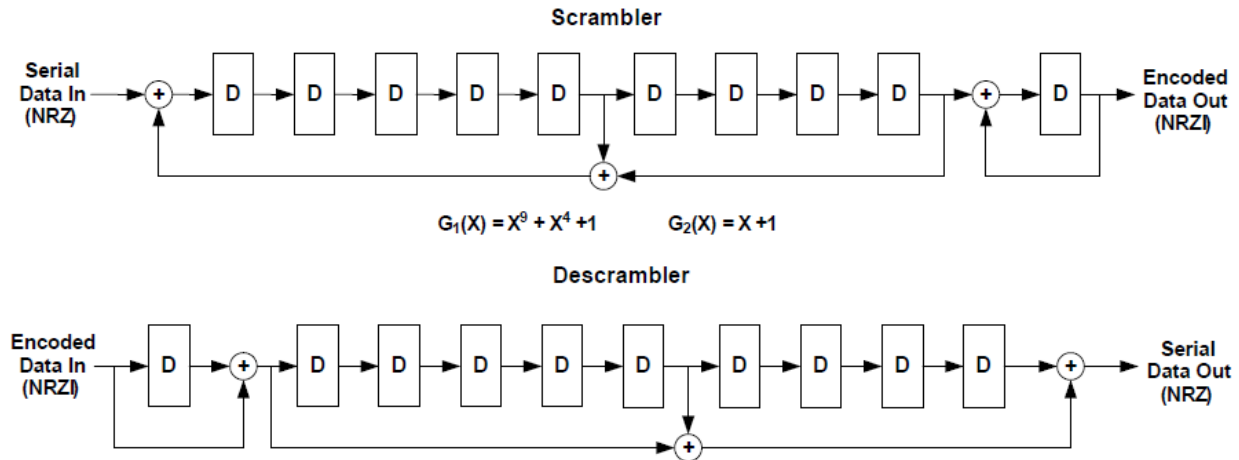

Figure B.1 – Possible Generator polynomial – Method 1

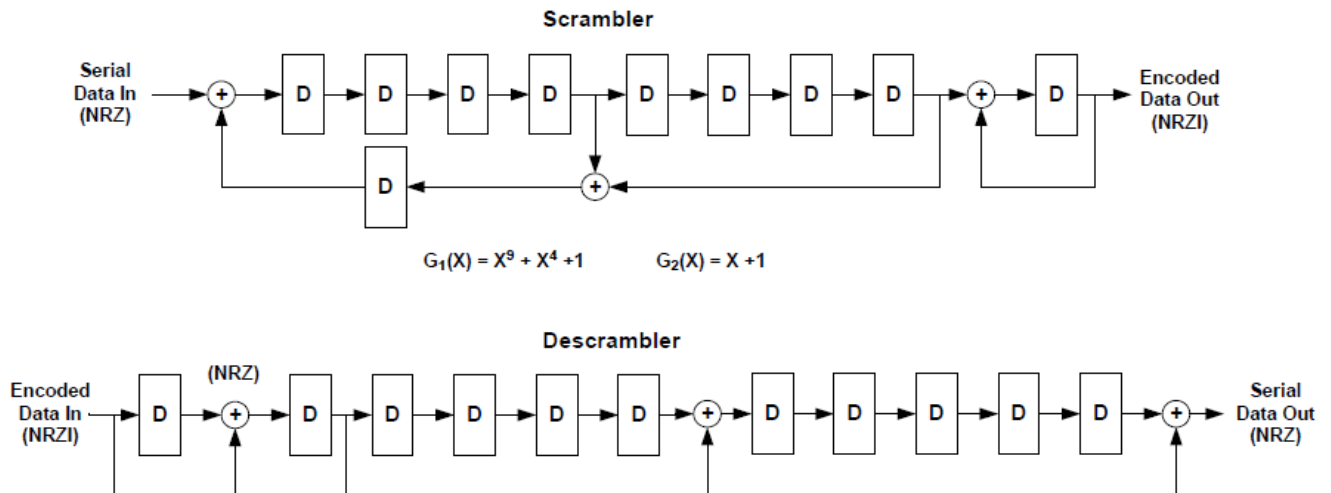

Figure B.2 – Possible Generator polynomial – Method 2

Annex C Pot-Hole Pathological and the Sync-Bit Insertion Process (Informative)

The concatenation of timing reference signal (TRS) preambles at the start and end of each line brought about by the 10-bit word multiplex defined in SMPTE ST 2082-10 for example, can result in a long run of zeros feeding the scrambling polynomial. This condition can result in the generation of the “Pot Hole Pathological” condition as described in the paper “Pathological Check Codes and the SMPTE Scrambler in the HD Age” published in the October 2011 edition of the SMPTE Motion Imaging Journal.

The concatenated TRS preambles for the Type 2 multiplex result in 8 consecutive words of 3FFh and 16 consecutive words of 000h. When serialized, this will result in 160 ones followed by 320 zeros at the input of the scrambler as shown in Figure C1.

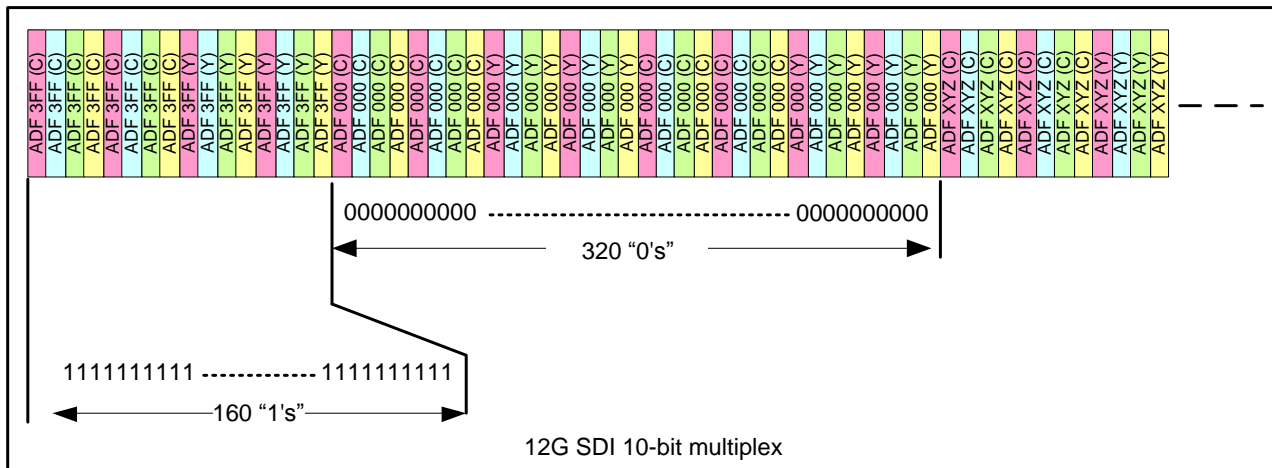

Figure C.1 – Pot hole pathological as a result of 10-bit word multiplex

If the scrambler registers are already at zero when this condition occurs, an additional 10 zero bits are added to the run-length.

In addition, the first XYZ word in the multiplexed stream could also be 200h, which when serialized LSB first, results in another 9 zeros.

Therefore, the maximum run of zeros output from the scrambling polynomial defined in Section 4.2 will be 339 (320 + 10 + 9). After NRZI is applied, this produces a long run of 339 zeros or ones in the 12G-SDI serialized data stream.

This condition occurs on average twice every 512 lines, i.e. many times per second. A long sequence of zeros when NRZI encoded to a long sequence of either zeros or ones, is potentially challenging to clock recovery circuits.

Similarly a long sequence of ones from the scrambler when NRZI coded produces a long sequence of transitions. The 12G-SDI signal then has a single frequency component at one half of the data rate. This signal is challenging to equalizing circuits.

Similar pot-hole conditions may also be created by the concatenation of the ancillary data flag (ADF) preamble contained in the 10-bit parallel data stream.

These long runs, although infrequent, can cause unwanted DC shifts on the 12G-SDI serialized link or may look like a loss of signal to receiving equipment.

The sync-bit insertion process defined in this standard reduces the pot-hole condition to a maximum of 20 consecutive zeros.

The modified preamble values, 3FDh, 3FEh, 001h, and 002h produced by the sync-bit insertion process, are still illegal video code words; they cannot appear within the active video data stream once the receiver has correctly synchronized and framed the serial data stream into 10-bit parallel data words.

It should be noted however that until word alignment is achieved in the receiver it is possible — although extremely unlikely — that similar data patterns can occur during the active line. The Sync-bit insertion process defined in this standard therefore retains one complete sequence of 3FFh, 000h, 000h code words. This sequence is always uniquely identifiable ensuring that framing in the receiver can be reliably performed.

Other 3FFh and 000h words can be modified without risking conflict with legal active video or ancillary data.