

SMPTE STANDARD

4320-line and 2160-line Source Image and Ancillary Data Mapping for Quad-link 12G-SDI



Page 1 of 42 pages

Table of Contents	Page
Foreword	3
Intellectual Property	3
Introduction.....	3
1 Scope	7
2 Conformance Notation	7
3 Normative References	8
4 Mode 1: Carriage of 4320-line Source Image Formats and Ancillary Data	8
4.1 Mapping	9
4.2 Intermediate Sub Image Mapping (Informative)	11
4.3 Ancillary Data	15
4.4 Audio Data	15
4.5 Time Code Data	17
4.6 Payload Identifier	17
4.7 Blanking (Informative)	20
4.8 Multiplex	21
4.9 Levels of Operation (Informative).....	21
5 MODE 2: Carriage of 2160-line R'G'B', Y'C _B C _R 4:4:4(4) 10-bit and 4:4:4 12-bit Additional Frame Rate (AFR) Source Image Formats and Ancillary Data	22
5.1 Mapping	23
5.2 Mapping of 1080-line Sub Images	24
5.3 Timing and Reference Signals.....	30
5.4 Line Numbers.....	30
5.5 Line CRC Codes	31
5.6 HANC and VANC Space of Data Streams.....	31

5.7	Audio Data	31
5.8	Time Code Data	34
5.9	Payload Identifier	35
5.10	Blanking	37
5.11	Multiplex	37
5.12	Levels of Operation (Informative).....	38
6	Quad-link 12G-SDI 10-bit Multiplex	38
7	12G-SDI Link 1 / 12G-SDI Link 2 / 12G-SDI Link 3 / 12G-SDI Link 4 Interface Timing	40
Annex A	Ancillary Data Capacity of the Quad-link 12G-SDI Interface (Informative)	41
Annex B	Bibliography (Informative)	42

Foreword

SMPTE (the Society of Motion Picture and Television Engineers) is an internationally-recognized standards developing organization. Headquartered and incorporated in the United States of America, SMPTE has members in over 80 countries on six continents. SMPTE's Engineering Documents, including Standards, Recommended Practices, and Engineering Guidelines, are prepared by SMPTE's Technology Committees. Participation in these Committees is open to all with a bona fide interest in their work. SMPTE cooperates closely with other standards-developing organizations, including ISO, IEC and ITU.

SMPTE Engineering Documents are drafted in accordance with the rules given in its Standards Operations Manual.

SMPTE ST 2082-12 was prepared by Technology Committee 32NF.

Intellectual Property

At the time of publication no notice had been received by SMPTE claiming patent rights essential to the implementation of this Engineering Document. However, attention is drawn to the possibility that some of the elements of this document may be the subject of patent rights. SMPTE shall not be held responsible for identifying any or all such patent rights.

Introduction

SMPTE ST 2082-12 defines the mapping of various source images and associated ancillary data into a Quad-link 12 Gb/s [nominal] SDI bit-serial interface.

The general process for creating a quad-link 12G-SDI is illustrated below in Figure 1 and Figure 2. Detailed definitions of how this process applies to each of the modes defined in the scope follow in other sections of this document.

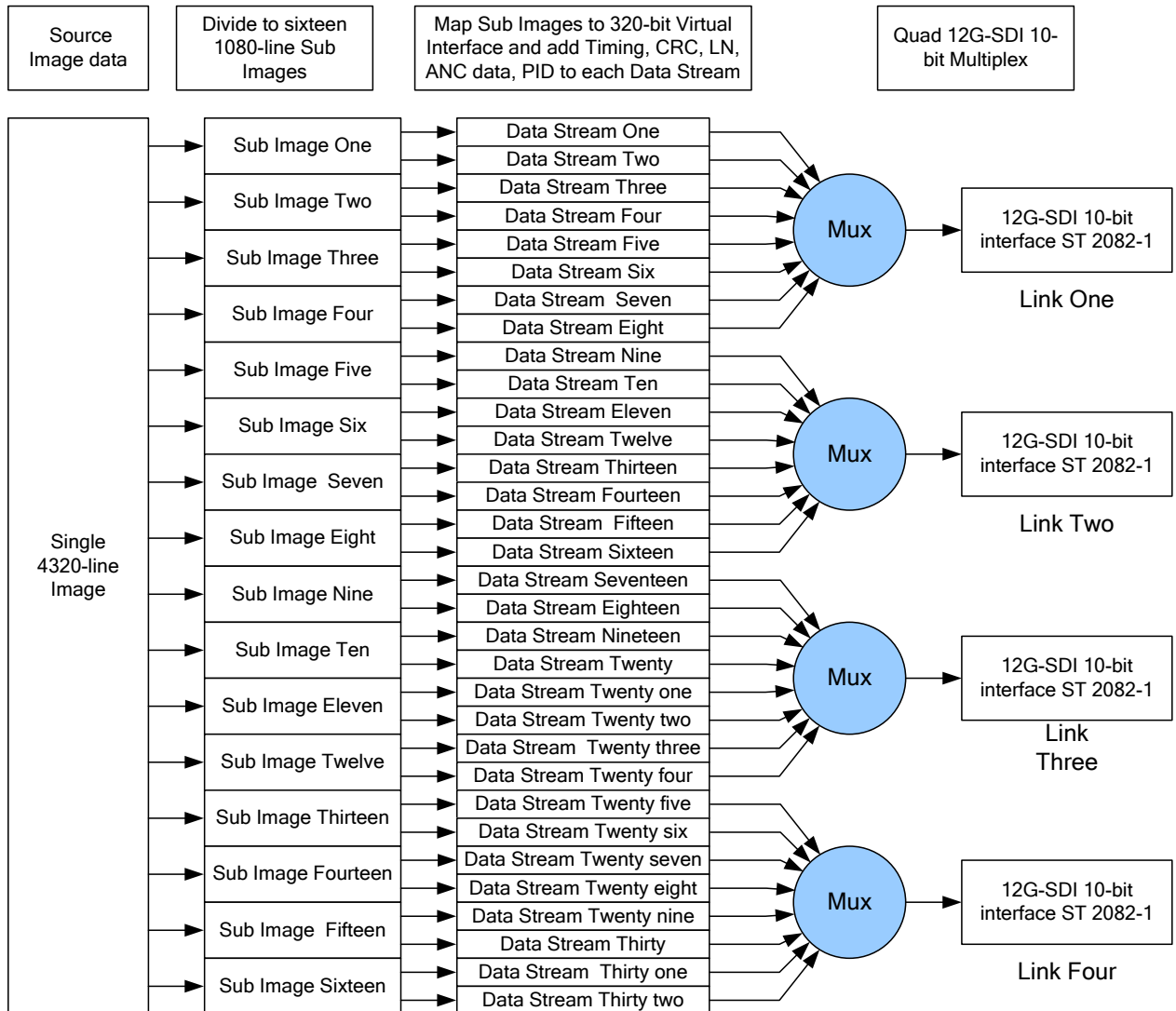

**Figure 1 – Carriage of 4320-line Images on a Quad-link 12G interface
— generalized process as used by Mode 1**

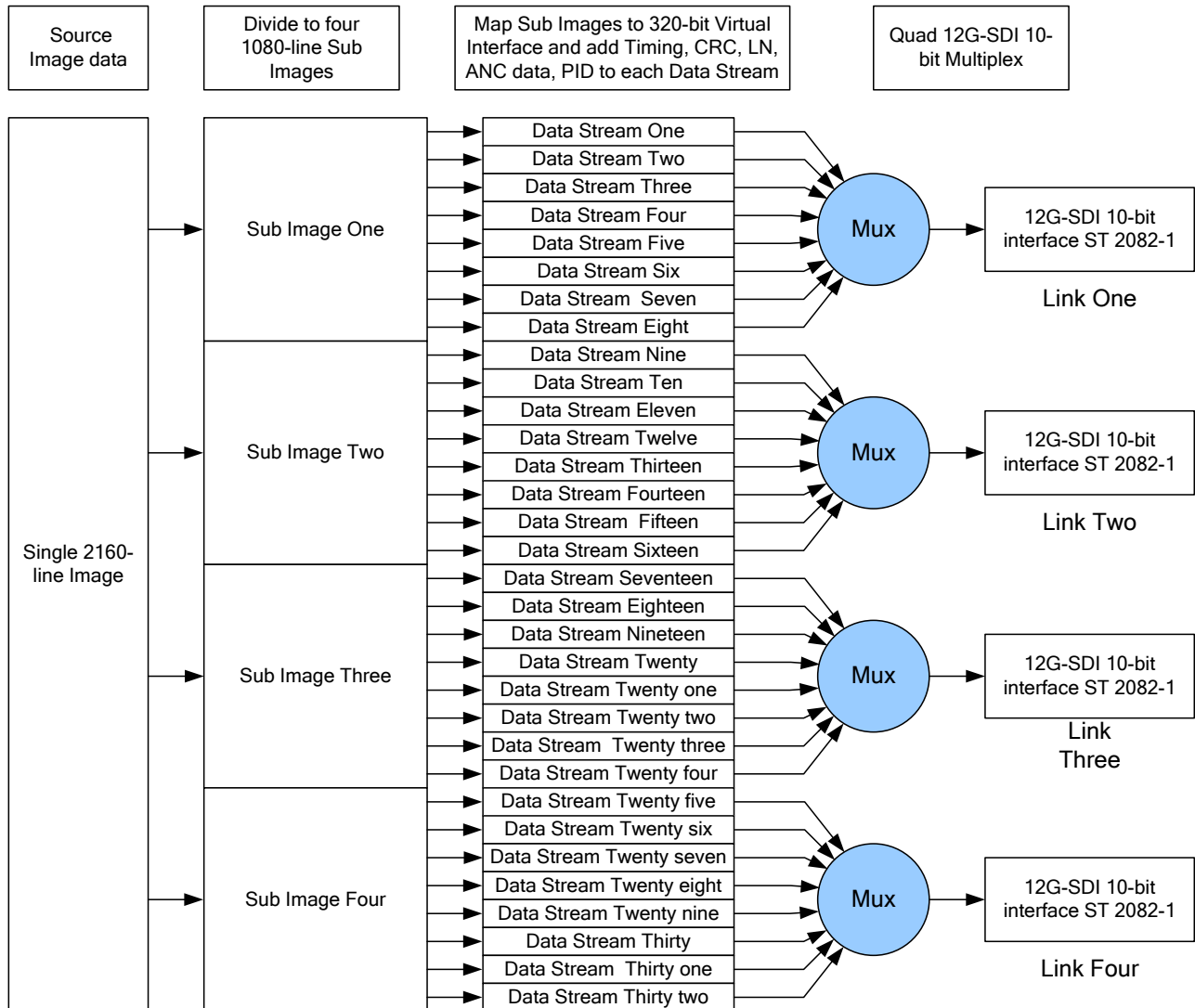

**Figure 2 – Carriage of 2160-line Images on a Quad-link 12G interface
— generalized process as used by Mode 2**

Formatting

The source images are divided into four or sixteen 1080-line sub images as appropriate to the source image format.

The sub images are then mapped on to a 320-bit virtual interface consisting of thirty two 10-bit data streams.

Each 10-bit data stream includes timing and sync words, line numbers, cyclic redundancy codes, ancillary data, including audio, and payload identification packets

Multiplex

The 320-bit virtual interface is then multiplexed onto four 12G-SDI 10-bit interfaces.

The first eight data streams are multiplexed in the order data stream eight, data stream four, data stream six, data stream two, data stream seven, data stream three, data stream five, data stream one...onto 12G-SDI Link 1.

The second eight data streams are multiplexed in the order data stream sixteen, data stream twelve, data stream fourteen, data stream ten, data stream fifteen data stream eleven, data stream thirteen data stream nine...onto 12G-SDI Link 2.

The third eight data streams are multiplexed in the order data stream twenty four, data stream twenty, data stream twenty two, data stream eighteen, data stream twenty three, data stream nineteen, data stream twenty one data stream seventeen...onto 12G-SDI Link 3.

The fourth eight data streams are multiplexed in the order data stream thirty two, data stream twenty eight, data stream thirty, data stream twenty six, data stream thirty one, data stream twenty seven, data stream twenty nine, data stream twenty five ...onto 12G-SDI Link 4.

1 Scope

This Standard defines the mapping of:

- **MODE 1:** 4320-line Source image formats and ancillary data into a Quad-link 12 Gb/s [nominal] SDI bit-serial interface
- **MODE 2:** 2160-line Y'C_BC_R' or R'G'B' 4:4:4 10-bit or 4:4:4 10-bit or 12-bit Additional Frame Rate (AFR) Source image formats and ancillary data into a Quad-link 12 Gb/s [nominal] SDI bit-serial interface

This Standard also defines the carriage of the SMPTE ST 352 payload ID's for the Quad-link 12Gb/s SDI interface.

It is not necessary for implementations to include support for all formats that are included in this Standard. Implementers should indicate supported formats in commercial publications.

2 Conformance Notation

Normative text is text that describes elements of the design that are indispensable or contains the conformance language keywords: "shall", "should", or "may". Informative text is text that is potentially helpful to the user, but not indispensable, and can be removed, changed, or added editorially without affecting interoperability. Informative text does not contain any conformance keywords.

All text in this document is, by default, normative, except: the Introduction, any section explicitly labeled as "Informative" or individual paragraphs that start with "Note:"

The keywords "shall" and "shall not" indicate requirements strictly to be followed in order to conform to the document and from which no deviation is permitted.

The keywords, "should" and "should not" indicate that, among several possibilities, one is recommended as particularly suitable, without mentioning or excluding others; or that a certain course of action is preferred but not necessarily required; or that (in the negative form) a certain possibility or course of action is deprecated but not prohibited.

The keywords "may" and "need not" indicate courses of action permissible within the limits of the document.

The keyword "reserved" indicates a provision that is not defined at this time, shall not be used, and may be defined in the future. The keyword "forbidden" indicates "reserved" and in addition indicates that the provision will never be defined in the future.

A conformant implementation according to this document is one that includes all mandatory provisions ("shall") and, if implemented, all recommended provisions ("should") as described. A conformant implementation need not implement optional provisions ("may") and need not implement them as described.

Unless otherwise specified, the order of precedence of the types of normative information in this document shall be as follows: Normative prose shall be the authoritative definition; Tables shall be next; followed by formal languages; then figures; and then any other language forms.

3 Normative References

The following standards contain provisions that, through reference in this text, constitute provisions of this standard. At the time of publication, the editions indicated were valid. All standards are subject to revision, and parties to agreements based on this standard are encouraged to investigate the possibility of applying the most recent edition of the standards indicated below.

SMPTE ST 12-2:2014, Transmission of Time Code in the Ancillary Data Space

SMPTE ST 12-3:2016, Time Code for High Frame Rate Signals and Formatting in the Ancillary Data Space

SMPTE ST 299-1:2009, 24-Bit Digital Audio Format for SMPTE 292 Bit-Serial Interface

SMPTE ST 299-2:2010, Extension of the 24-Bit Digital Audio Format to 32 Channels for 3 Gb/s Bit-Serial Interfaces

SMPTE ST 352:2013, Payload Identification Codes for Serial Digital Interfaces

SMPTE ST 425-5:2015, Image Format and Ancillary Data Mapping for the Quad Link 3 Gb/s Serial Interface

SMPTE ST 2036-1:2014, Ultra High Definition Television — Image Parameter Values for Program Production

SMPTE ST 2048-1:2011, 2048 × 1080 and 4096 × 2160 Digital Cinematography Production Image Formats FS/709

Amendment 1:2016 to SMPTE ST 2048-1:2011

SMPTE ST 2082-10:2015, 2160-line Source Image and Ancillary Data Mapping for 12G-SDI

4 Mode 1: Carriage of 4320-line Source Image Formats and Ancillary Data

In the case of 4320-line mapping, the image formats supported are defined in Table 1.

Table 1 – Supported Image sample structures and frame rates

Reference SMPTE Standard	Image Format	Signal Format Sampling Structure/pixel Depth	Frame Rate
ST 2036-1	7680 x 4320	4:2:2 (Y'C _B C _R), 4:2:0 (Y'C _B C _R)/10-bit	50, 60/1.001 and 60 Progressive
ST 2036-1	7680 x 4320	4:4:4 (R'G'B')/10-bit	24/1.001, 24, 25, 30/1.001 and 30 Progressive
ST 2036-1	7680 x 4320	4:4:4 (Y'C _B C _R)/10-bit	
ST 2036-1	7680 x 4320	4:4:4 (R'G'B')/12-bit	
ST 2036-1	7680 x 4320	4:4:4 (Y'C _B C _R)/12-bit	
ST 2036-1	7680 x 4320	4:2:2 (Y'C _B C _R)/12-bit 4:2:0 (Y'C _B C _R)/12-bit	

4.1 Mapping

The 4320-line image shall be divided into four 2160-line intermediate sub images in accordance with the 2 sample interleave sub-division method as shown in Figure 3.

For 4:2:0 source images, the 10-bit C'_B and C'_R samples in intermediate sub images 3 and 4 are set to the value 200h and the 12-bit C'_B and C'_R samples in intermediate sub images 3 and 4 are set to the value 800h.

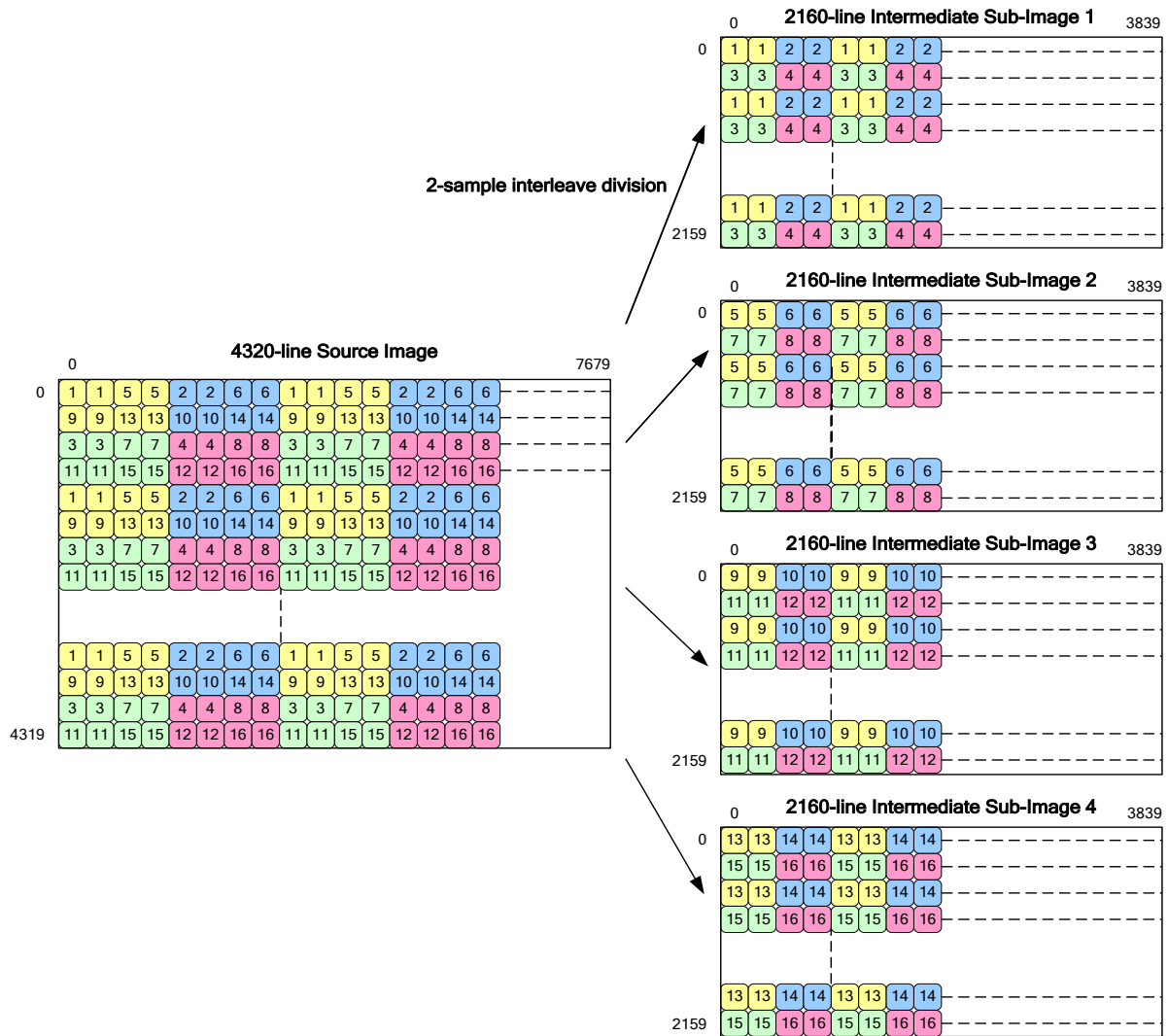

Figure 3 – Two sample division of a 4320-line image to four 2160-line intermediate sub images

Each 2160-line intermediate sub image shall then be divided into four 1080-line sub images and mapped to an 80-bit virtual interface according to SMPTE ST 2082-10 “2160-line Source Image and Ancillary Data Mapping for 12G-SDI” mode 1 “Carriage of 2160-line Source image formats and ancillary data” as illustrated in Figure 4.

Intermediate sub image 1 shall be divided to sub images 1 through 4 and mapped to data streams one through eight.

Intermediate sub image 2 shall be divided to sub images 5 through 8 and mapped to data streams nine through sixteen.

Intermediate sub image 3 shall be divided to sub images 9 through 12 and mapped to data streams seventeen through twenty four.

Intermediate sub image 4 shall be divided to sub images 13 through 16 and mapped to data streams twenty five through thirty two.

Note: For 4:2:0 source images, the 10-bit C'_B and C'_R samples in sub images 9 through 16 are set to the value 200h and the 12-bit C'_B and C'_R samples in sub images 9 through 16 are set to the value 800h.

The thirty two 10-bit data streams so constructed shall each contain timing reference code words (SAV/EAV), line numbers and line based CRC's as defined in SMPTE ST 2082-10 Mode 1 2160-line Mapping.

The thirty two data streams, data stream one through data stream thirty two, shall be combined into a 320-bit virtual interface.

The virtual interface shall contain ancillary data and audio as defined elsewhere in this standard.

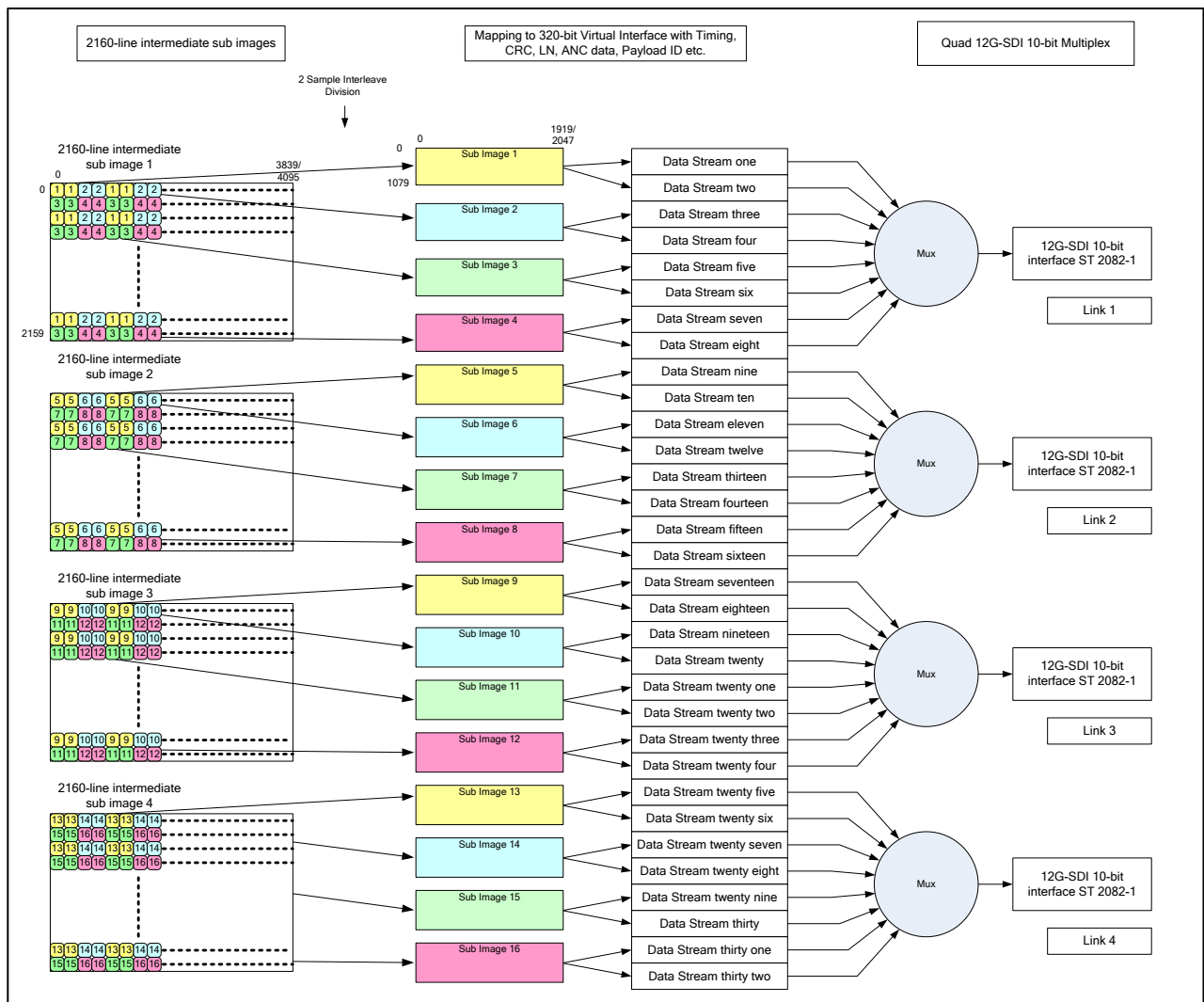

Figure 4 – 2 sample division of the four 2160-line intermediate sub images to sixteen 1080-line sub images, and mapping into a quad-link 12G-SDI interface

4.2 Intermediate Sub Image Mapping (Informative)

Each 2160-line intermediate sub-image is divided to four 1080-line sub-images in accordance with SMPTE ST 2082-10 Mode 1 using the 2 sample interleave sub-division method referenced in SMPTE ST 425-5 “2160-line image division into four sub images”.

Each 1080-line sub image conforms to the SMPTE ST 274 sub image formats shown in Table 2.

Table 2 – 1080-line Sub Image Formats for 4320-line Source Images

Source Image		Sub Image	
Reference SMPTE Standard	Image Format	Reference SMPTE Standard	Image Format
ST 2036-1	7680 × 4320	ST 274	1920 × 1080

Each 1080-line sub-image is mapped into a 20-bit virtual interface consisting of two 10-bit data streams.

Sub image 1 is mapped into data streams one and two.

Sub image 2 is mapped into data streams three and four.

Sub image 3 is mapped into data streams five and six.

Sub image 4 is mapped into data streams seven and eight.

Sub image 5 is mapped into data streams nine and ten.

Sub image 6 is mapped into data streams eleven and twelve.

Sub image 7 is mapped into data streams thirteen and fourteen.

Sub image 8 is mapped into data streams fifteen and sixteen.

Sub image 9 is mapped into data streams seventeen and eighteen.

Sub image 10 is mapped into data streams nineteen and twenty.

Sub image 11 is mapped into data streams twenty one and twenty two.

Sub image 12 is mapped into data streams twenty three and twenty four.

Sub image 13 is mapped into data streams twenty five and twenty six.

Sub image 14 is mapped into data streams twenty seven and twenty eight.

Sub image 15 is mapped into data streams twenty nine and thirty.

Sub image 16 is mapped into data streams thirty one and thirty two

Each of the thirty two 10-bit data streams so constructed contains timing reference code words (SAV/EAV), line numbers and line based CRC's as defined in SMPTE ST 425-5 2160-line Mapping.

4.2.1 4320-line 320-bit Virtual Interface Multiplex Structure (Informative)

The video data words from each sub image are conveyed in the following order in the data streams of the 320-bit virtual interface:

Mapping Structure 1:

Sub image 1 is mapped into data streams one and two:

data stream one: $Y'0, Y'1, Y'2, Y'3...$

data stream two: $C'_B0, C'_R0, C'_B1, C'_R1...$

Sub image 2 is mapped into data streams three and four:

data stream three: $Y'0, Y'1, Y'2, Y'3...$

data stream four: $C'_B0, C'_R0, C'_B1, C'_R1...$

Sub image 3 is mapped into data streams five and six:

data stream five: $Y'0, Y'1, Y'2, Y'3...$

data stream six: $C'_B0, C'_R0, C'_B1, C'_R1...$

Sub image 4 is mapped into data streams seven and eight:

data stream seven: $Y'0, Y'1, Y'2, Y'3...$

data stream eight: $C'_B0, C'_R0, C'_B1, C'_R1...$

Sub image 5 is mapped into data streams nine and ten:

data stream nine: $Y'0, Y'1, Y'2, Y'3...$

data stream ten: $C'_B0, C'_R0, C'_B1, C'_R1...$

Sub image 6 is similarly mapped into data streams eleven and twelve

Sub image 7 is similarly mapped into data streams thirteen and fourteen

Sub image 8 is similarly mapped into data streams fifteen and sixteen

Sub image 9 is similarly mapped into data streams seventeen and eighteen

Sub image 10 is similarly mapped into data streams nineteen and twenty

Sub image 11 is similarly mapped into data streams twenty one and twenty two

Sub image 12 is similarly mapped into data streams twenty three and twenty four

Sub image 13 is similarly mapped into data streams twenty five and twenty six

Sub image 14 is similarly mapped into data streams twenty seven and twenty eight

Sub image 15 is similarly mapped into data streams twenty nine and thirty

Sub image 16 is similarly mapped into data streams thirty one and thirty two

For a 4:2:0 source images, the 10-bit C'_B and C'_R samples in sub images 9 through 16 are set to the value 200h.

Mapping Structure 2:

Sub image 1 is mapped into data streams one and two:

data stream one: $G'0, R'0, G'1, R'1...$

data stream two: $A0, B'0, A1, B'1...$

Sub image 2 is mapped into data streams three and four:

data stream three: $G'0, R'0, G'1, R'1...$

data stream four: $A0, B'0, A1, B'1...$

Sub image 3 is mapped into data streams five and six:

data stream five: G'0, R'0, G'1, R'1...

data stream six: A0, B'0, A1, B'1...

Sub image 4 is mapped into data streams seven and eight:

data stream seven: G'0, R'0, G'1, R'1...

data stream eight: A0, B'0, A1, B'1...

Sub image 5 is mapped into data streams nine and ten:

data stream nine: G'0, R'0, G'1, R'1...

data stream ten: A0, B'0, A1, B'1...

Sub image 6 is similarly mapped into data streams eleven and twelve

Sub image 7 is similarly mapped into data streams thirteen and fourteen

Sub image 8 is similarly mapped into data streams fifteen and sixteen

Sub image 9 is similarly mapped into data streams seventeen and eighteen

Sub image 10 is similarly mapped into data streams nineteen and twenty

Sub image 11 is similarly mapped into data streams twenty one and twenty two

Sub image 12 is similarly mapped into data streams twenty three and twenty four

Sub image 13 is similarly mapped into data streams twenty five and twenty six

Sub image 14 is similarly mapped into data streams twenty seven and twenty eight

Sub image 15 is similarly mapped into data streams twenty nine and thirty

Sub image 16 is similarly mapped into data streams thirty one and thirty two

Mapping Structure 3:

Bit b9 in every word is the complement of b8. The lists and tables below describe Bits b8 – b0

Sub image 1 is mapped into data streams one and two:

data stream one: R'G'B'0 [11:9], R'G'B'0 [5:3], R'G'B'1 [11:9], R'G'B'1 [5:3]...

data stream two: R'G'B'0 [8:6], R'G'B'0 [2:0], R'G'B'1 [8:6], R'G'B'1 [2:0]...

Sub image 2 is mapped into data streams three and four:

data stream three: R'G'B'0 [11:9], R'G'B'0 [5:3], R'G'B'1 [11:9], R'G'B'1 [5:3]...

data stream four: R'G'B'0 [8:6], R'G'B'0 [2:0], R'G'B'1 [8:6], R'G'B'1 [2:0]...

Sub image 3 is mapped into data streams five and six:

data stream five: R'G'B'0 [11:9], R'G'B'0 [5:3], R'G'B'1 [11:9], R'G'B'1 [5:3]...

data stream six: R'G'B'0 [8:6], R'G'B'0 [2:0], R'G'B'1 [8:6], R'G'B'1 [2:0]...

Sub image 4 is mapped into data streams seven and eight:

data stream seven: R'G'B'0 [11:9], R'G'B'0 [5:3], R'G'B'1 [11:9], R'G'B'1 [5:3]...

data stream eight: R'G'B'0 [8:6], R'G'B'0 [2:0], R'G'B'1 [8:6], R'G'B'1 [2:0]...

Sub image 5 is similarly mapped into data streams nine and ten

Sub image 6 is similarly mapped into data streams eleven and twelve

Sub image 7 is similarly mapped into data streams thirteen and fourteen

Sub image 8 is similarly mapped into data streams fifteen and sixteen

Sub image 9 is similarly mapped into data streams seventeen and eighteen

Sub image 10 is similarly mapped into data streams nineteen and twenty

Sub image 11 is similarly mapped into data streams twenty one and twenty two

Sub image 12 is similarly mapped into data streams twenty three and twenty four

Sub image 13 is similarly mapped into data streams twenty five and twenty six

Sub image 14 is similarly mapped into data streams twenty seven and twenty eight

Sub image 15 is similarly mapped into data streams twenty nine and thirty

Sub image 16 is similarly mapped into data streams thirty one and thirty two

Mapping Structure 4:

Bit b9 in every word is the complement of b8. The lists and tables below describe Bits b8 – b0

Sub image 1 is mapped into data streams one and two:

data stream one:	Bits b8 – b6:	A0 [11:9],	A0 [5:3],	A1 [11:9],	A1 [5:3]...
	Bits b5 – b0:	Y'0 [11:6],	Y'0 [5:0],	Y'1 [11:6],	Y'1 [5:0]...
data stream two:	Bits b8 – b6:	A0 [8:6],	A0 [2:0],	A1 [8:6],	A1 [2:0]...
	Bits b5 – b0:	C'b0 [11:6],	C'b0 [5:0],	C'r0 [11:6],	C'r0 [5:0]...

Sub image 2 is mapped into data streams three and four:

data stream three:	Bits b8 – b6:	A0 [11:9],	A0 [5:3],	A1 [11:9],	A1 [5:3]...
	Bits b5 – b0:	Y'0 [11:6],	Y'0 [5:0],	Y'1 [11:6],	Y'1 [5:0]...
data stream four:	Bits b8 – b6:	A0 [8:6],	A0 [2:0],	A1 [8:6],	A1 [2:0]...
	Bits b5 – b0:	C'b0 [11:6],	C'b0 [5:0],	C'r0 [11:6],	C'r0 [5:0]...

Sub image 3 is mapped into data streams five and six:

data stream five:	Bits b8 – b6:	A0 [11:9],	A0 [5:3],	A1 [11:9],	A1 [5:3]...
	Bits b5 – b0:	Y'0 [11:6],	Y'0 [5:0],	Y'1 [11:6],	Y'1 [5:0]...
data stream six:	Bits b8 – b6:	A0 [8:6],	A0 [2:0],	A1 [8:6],	A1 [2:0]...
	Bits b5 – b0:	C'b0 [11:6],	C'b0 [5:0],	C'r0 [11:6],	C'r0 [5:0]...

Sub image 4 is mapped into data streams seven and eight:

data stream seven:	Bits b8 – b6:	A0 [11:9],	A0 [5:3],	A1 [11:9],	A1 [5:3]...
	Bits b5 – b0:	Y'0 [11:6],	Y'0 [5:0],	Y'1 [11:6],	Y'1 [5:0]...

data stream eight: Bits b8 – b6: A0 [8:6], A0 [2:0], A1 [8:6], A1 [2:0]...
 Bits b5 – b0: C'_B0 [11:6], C'_B0 [5:0], C'_R0 [11:6], C'_R0 [5:0]...

Sub image 5 is similarly mapped into data streams nine and ten

Sub image 6 is similarly mapped into data streams eleven and twelve

Sub image 7 is similarly mapped into data streams thirteen and fourteen

Sub image 8 is similarly mapped into data streams fifteen and sixteen

Sub image 9 is similarly mapped into data streams seventeen and eighteen

Sub image 10 is similarly mapped into data streams nineteen and twenty

Sub image 11 is similarly mapped into data streams twenty one and twenty two

Sub image 12 is similarly mapped into data streams twenty three and twenty four

Sub image 13 is similarly mapped into data streams twenty five and twenty six

Sub image 14 is similarly mapped into data streams twenty seven and twenty eight

Sub image 15 is similarly mapped into data streams twenty nine and thirty

Sub image 16 is similarly mapped into data streams thirty one and thirty two

For a 4:2:0 source image, the 12-bit C'_B and C'_R samples in sub images 9 through 16 are set to the value 800h.

4.3 Ancillary Data

When present, ancillary data packets shall be mapped into the HANC or the VANC spaces of each data stream. The HANC and VANC spaces of each sub image are defined in the reference standard for each sub image format referenced in SMPTE ST 425-5 Table 2.

Unless otherwise stated, the ancillary data shall be preferentially mapped into data stream one first and any remaining data shall then be mapped onto data stream three; then into data stream five, data stream seven and successive odd numbered data streams up to data stream thirty one. In some cases it is required by specific applications that ancillary data be mapped into all thirty two data streams (e.g. Payload ID.)

Informative Annex A provides information about the amount of HANC and VANC data space available in this operating mode.

4.4 Audio Data

When present, audio data shall be mapped into the HANC space of data streams one through thirty two and shall be in conformance with SMPTE ST 299-1 and SMPTE ST 299-2.

Audio control packets shall be mapped into the odd numbered data streams.

Audio data packets shall be mapped into the even numbered data streams.

Audio control and data packets shall be mapped into the data stream pair one/two first and any remaining data shall then be mapped onto data stream pair three/four, then into data stream pair five/six and finally into data stream pair thirty one/thirty two.

The audio clock phase data as defined in the section “CLK (audio clock phase data)” of SMPTE ST 299-1 shall be calculated at the clock frequency of 148.5 (/1.001) MHz for 4:2:2 10-bit and 4:2:0 10-bit formats at 48/1.001, 48, 50, 60/1.001 and 60 Hz, which use Mapping Structure 1.

The audio clock phase data as defined in the section “CLK (audio clock phase data)” of SMPTE ST 299-1 shall be calculated at the clock frequency of 74.25 (/1.001) MHz for formats at 24/1.001, 24, 25, 30/1.001 or 30Hz, which use Mapping Structure 2, 3 or 4.

Note: Some audio applications use non-PCM audio data. These may require the use of a marker as defined in SMPTE ST 2051 (see Bibliography) to indicate which frame contains the SDI switching point for the non-PCM data payload.

4.4.1 Number of Audio Channels

Up to 512 audio channels sampled at 32 kHz, 44.1 kHz or 48 kHz may be mapped into data streams one through thirty two of the 320-bit virtual interface. At 96 kHz sampling, up to 256 audio channels may be mapped into the virtual interface.

4.4.1.1 Carriage of up to 512 Channels of Audio at up to 48 kHz Sampling

For audio at up to 48 kHz sampling, the audio data and control for the first 16 channels shall be mapped into data stream pair one/two in conformance with SMPTE ST 299-1 (audio groups 1 to 4).

The extended audio data and control packets for the second 16 channels shall be mapped into data stream pair one/two in conformance with SMPTE ST 299-2 (audio groups 5 to 8).

The audio data and control packets for the third 16 channels shall be mapped into data stream pair three/four in conformance with SMPTE ST 299-1 (audio groups 1 to 4).

The extended audio data and control packets for the fourth 16 channels shall be mapped into data stream pair three/four in conformance with SMPTE ST 299-2 (audio groups 5 to 8).

Successive sets of 32 channels shall be mapped into successive data stream pairs, up to...

The audio data and control packets for the thirty first 16 channels shall be mapped into data stream thirty one/thirty two in conformance with SMPTE ST 299-1 (audio groups 1 to 4).

The extended audio data and control packets for the thirty second 16 channels shall be mapped into data stream thirty one/thirty two in conformance with SMPTE ST 299-2 (audio groups 5 to 8).

4.4.1.2 Carriage of up to 256 Channels of Audio at 96 kHz Sampling

For audio at 96 kHz sampling, the audio data and control packets for the first 8 channels shall be mapped into data stream pair one/two in conformance with SMPTE ST 299-1 (audio groups 1 to 4).

The extended audio data and control packets for the second 8 channels shall be mapped into data stream pair one/two in conformance with SMPTE ST 299-2 (audio groups 5 to 8).

The audio data and control packets for the third 8 channels shall be mapped into data stream pair three/four in conformance with SMPTE ST 299-1 (audio groups 1 to 4).

The extended audio data and control packets for the fourth 8 channels shall be mapped into data stream pair three/four in conformance with SMPTE ST 299-2 (audio groups 5 to 8).

Successive sets of 16 channels shall be mapped into successive data stream pairs, up to...

The audio data and control packets for the thirty first 8 channels shall be mapped into data stream thirty one/thirty two in conformance with SMPTE ST 299-1 (audio groups 1 to 4).

The extended audio data and control packets for the thirty second 8 channels shall be mapped into data stream thirty one/thirty two in conformance with SMPTE ST 299-2 (audio groups 5 to 8).

4.4.2 Audio Copy

As an alternative to the mapping of the maximum number of unique audio channels described above, blocks of audio channels may be copied within the interface. This may be done in order for Links 2, 3 and 4 to carry a copy of the audio on Link 1.

Note: Audio copy reduces the number of channels that can be transported by the interface.

If audio is copied:

Data streams one through eight shall always carry original audio.

Data streams nine through sixteen may also carry original audio.

Data streams seventeen through thirty two may carry copied audio from data streams one through sixteen.

Data streams nine through sixteen may carry copied audio from data streams one through eight. In this case data streams seventeen through twenty four, and data streams twenty five through thirty two shall also carry the same copied audio.

The audio copy status of each data stream shall be signaled in the PID for that data stream as described in Section 4.6

4.5 Time Code Data

When present the time code shall be mapped into the HANC space of data stream one, and shall be in conformance with SMPTE ST 12-2.

The time code may also be mapped onto data stream three, data stream five, data stream seven, and so on up to data stream thirty one, in which case the corresponding Time Address values shall be identical.

4.6 Payload Identifier

Table 3 shows the payload identifier definitions for 4320-line Video Payloads. As stated in SMPTE ST 352, the payload identifier consists of 4 bytes where each byte has a separate significance. The first byte of the payload identifier has the highest significance and subsequent bytes define lower order video and ancillary payload information.

The horizontal placement of the packet should be immediately following the last CRC code word (CR1) of the line(s) specified in SMPTE ST 352 for 1125-line systems.

Note: The line numbers defined in SMPTE ST 352 for the placement of the payload identifier packet in 1125-line systems avoid those lines used by SMPTE ST 299-1 and SMPTE ST 299-2 for the carriage of digital audio control packets and extended audio control packets, respectively.

Table 3 – Payload Identifier Definitions for 4320-line Video Payload for Mapping on a Quad-link 12Gb/s (nominal) Serial Interface

Bits	Byte 1	Byte 2	Byte 3	Byte 4
Bit 7	1	Progressive transport (1)	Aspect Ratio 16:9 (1) or Unknown (0)	Link assignment 12G-SDI Link 1 (0h) 12G-SDI Link 2 (1h) 12G-SDI Link 3 (2h) 12G-SDI Link 4 (3h)
Bit 6	1	Progressive picture (1)	Sub image horizontal sampling 1920 (0)	
Bit 5	0	Reserved (0)	Colorimetry Rec 709* ¹ (0h) Reserved (1h) UHDTV* ² (2h) Unknown (3h)	
Bit 4	1	Reserved (0)		Reserved (0)
Bit 3	0	Picture rate (See Table 4)	Sampling structure (See Table 5)	Reserved (0)
Bit 2	0			Audio copy status: Audio in this data stream carries additional channels or audio not present (0) Audio in this data stream is copied (1)
Bit 1	1			Bit depth 10-bit (1h) 12-bit (2h) Other values are Reserved
Bit 0	0			

Notes:

*1 Rec 709 indicates ITU-R recommendation BT.709 colorimetry and is equivalent to SMPTE ST 2036-1 Conventional System Colorimetry.

*2 UHDTV indicates SMPTE ST 2036-1 UHDTV colorimetry and is equivalent to ITU-R recommendation BT.2020 colorimetry.

4.6.1 Byte 1 – Digital Interface and Payload Identification

Byte 1 of the payload identifier identifies the video payload and the digital interface and shall be as defined below.

Byte 1 shall be set to [D2h] for 4320-line image formats listed in Table 1 transported via quad-link 12G-SDI.

4.6.2 Byte 2 – Picture Rate and Scanning Method

Byte 2 of the payload identifier shall be used to identify the picture and transport scanning methods and the picture rate.

Bit b7 shall be set to 1 (progressive transport).

Bit b6 shall be set to 1 (progressive picture).

Bit b5 shall be set to 0 (reserved).

Bit b4 shall be set to 0 (reserved).

Bits b3 to b0 shall be used to identify the picture rate in Hz according to Table 4 and shall only use the values as permitted for image formats listed in Table 1.

Table 4 – SMPTE ST 352 Byte 2 Picture rate extended to include additional picture (frame) rates

Value	Picture rate Hz	Value	Picture rate Hz	Value	Picture rate Hz	Value	Picture rate Hz
0h	Not defined	1h	96/1.001	2h	24/1.001	3h	24
4h	48/1.001	5h	25	6h	30/1.001	7h	30
8h	48	9h	50	Ah	60/1.001	Bh	60
Ch	96	Dh	100	Eh	120/1.001	Fh	120

4.6.3 Byte 3 – Sampling Structure, Aspect Ratio and Horizontal Size

Byte 3 of the payload identifier shall be used to identify the aspect ratio, horizontal pixel array size, and sampling structure of the sub image video payload.

Bit b7 shall be used to identify the aspect ratio such that:

b7 = 0 shall identify unknown aspect ratio

b7 = 1 shall identify a 16:9 aspect ratio

Bit b6 shall be used to identify the number of active Luma/R'G'B' samples for the sub image such that:

b6 = 0 shall identify 1920 active Luma/R'G'B' samples

Bits b5 and b4 shall identify the colorimetry for the image formats identified in Table 1 such that:

b5:b4 = 0h shall identify Rec 709 colorimetry

b5:b4 = 1h shall be reserved

b5:b4 = 2h shall identify UHDTV colorimetry

b5:b4 = 3h shall identify unknown colorimetry

Bits b3 to b0 shall be used to identify the sampling structure in accordance with Table 5 and shall only use the values as permitted for image formats in Table 1.

Table 5 – SMPTE ST 352 Byte 3 Sampling Structure

Value	Sampling	Value	Sampling	Value	Sampling	Value	Sampling
0h	4:2:2 (Y'C _B C _R)	1h	4:4:4 (Y'C _B C _R)	2h	4:4:4 (R'G'B')	3h	4:2:0 (Y'C _B C _R)
4h	4:2:2:4 (Y'C _B C _R +A)	5h	4:4:4:4 (Y'C _B C _R +A)	6h	4:4:4:4 (R'G'B'+A)	7h	Reserved
8h	4:2:2:4 (Y'C _B C _R +D)	9h	4:4:4:4 (Y'C _B C _R +D)	Ah	4:4:4:4 (R'G'B'+D)	Bh	Reserved
Ch	Reserved	Dh	Reserved	Eh	4:4:4 (X'Y'Z')	Fh	Reserved

4.6.4 Byte 4 – Link assignment Identification, Audio copy status and Quantization Bit Depth

Byte 4 of the payload identifier shall be used to identify the link assignment, the audio copy status and the bit depth of the sample quantization.

Bits b7 to b5 shall be used to identify Link assignment and set to:

b7:b5 = 0h shall identify 12G-SDI Link 1

b7:b5 = 1h shall identify 12G-SDI Link 2

b7:b5 = 2h shall identify 12G-SDI Link 3

b7:b5 = 3h shall identify 12G-SDI Link 4

Bit b4 shall be reserved and set to 0

Bit b3 shall be reserved and set to 0

For data streams one through eight bit b2 shall be set to 0 (reserved)

For data streams nine through thirty two bit b2 shall be used to identify whether audio data in this data stream is copied:

b2 = 0 shall identify that all audio if present in this data stream carries additional channels

b2 = 1 shall identify that audio if present in this data stream is copied

Bits b1 to b0 shall be used to identify the bit depth of the sample quantization such that:

b1:b0 = 1h shall identify quantization using 10 bits per sample

b1:b0 = 2h shall identify quantization using 12 bits per sample

Other values shall be reserved.

4.7 Blanking (Informative)

As defined in the sub image source format document SMPTE ST 274, HANC and VANC spaces with no ancillary data packets or audio data packets contain data words that represent video black level for the video structure being carried.

In the case of Mapping Structure 1, 4:2:2 Y'C_BC_R 10-bit video structure, all words in odd numbered data stream take the value 040h and all words in even numbered data streams take the value 200h

In the case of Mapping Structure 2, 4:4:4(:4) R'G'B'(+A) 10-bit video structure, all words of all data streams take the value 040h

In the case of Mapping Structure 2, 4:4:4(:4) Y'C_BC_R(+A) 10-bit video structure, even numbered words in each data stream take the value 040h, and odd numbered words in each data stream take the value 200h

In the case of Mapping Structure 3, 4:4:4 R'G'B' 12-bit video structure, all words in odd numbered data streams take the value 200h, even numbered words in even numbered data streams take the value 224h, and odd numbered words in even numbered data streams take the value 200h

In the case of Mapping Structure 3, 4:4:4 Y'C_BC_R 12-bit video structure, even numbered words in odd numbered data streams take the value 104h, odd numbered words in odd numbered data streams take the value 200h, even numbered words in even numbered data streams take the value 220h, and odd numbered words in even numbered data streams take the value 200h

In the case of Mapping Structure 4, 4:2:2(:4) Y'C_B'C_R 12-bit video structure, even numbered words in odd numbered data streams take the value 204h, odd numbered words in odd numbered data streams take the value 200h, even numbered words in even numbered data streams take the value 120h, and odd numbered words in even numbered data streams take the value 200h

Note: Word numbering starts at the first word of active video which is numbered zero and is an even numbered word. Word numbering refers to the 10-bit words which make up each data stream and is not the same as sample numbering.

4.8 Multiplex

The 320-bit virtual interface shall then be multiplexed onto four Type 1 12G-SDI 10-bit interfaces according to Section 6.

4.9 Levels of Operation (Informative)

To define the level of support for SMPTE ST 2082-12 Mode 1, manufacturers are encouraged to indicate in publications which mapping format is supported. For example:

SMPTE ST 2082-12 MODE 1 – 4320-line Source image formats and ancillary data into a Quad-link 12 Gb/s [nominal] SDI bit-serial interface

Manufacturers are also encouraged to indicate in publications supported audio and video formats.

5 MODE 2: Carriage of 2160-line R'G'B', Y'C_BC_R 4:4:4(:4) 10-bit and 4:4:4 12-bit Additional Frame Rate (AFR) Source Image Formats and Ancillary Data

For this mode, the Source Image Formats shall be as defined in Table 6.

Table 6 – Supported Image sample structures and frame rates

SMPTE Standard	Format	Signal Format Sampling Structure/pixel Depth	Additional Frame Rates (AFR)	Sub Image Mapping Structure
ST 2036-1	3840 x 2160	4:4:4 (R'G'B')/10-bit 4:4:4:4 (R'G'B'+A)/10-bit 4:4:4 (Y'C _B C _R)/10-bit 4:4:4:4 (Y'C _B C _R +A)/10-bit	120 frames progressive	
			120/1.001 frames progressive	
			100 frames progressive	
ST 2048-1	4096 x 2160* ²	4:4:4 (R'G'B'* ¹), 4:4:4:4 (R'G'B'* ¹ +A)/10-bit, 4:4:4 (Y'C _B C _R), 4:4:4:4 (Y'C _B C _R +A)/10-bit	120 frames progressive	II
			120/1.001 frames progressive	
			100 frames progressive	
			96 frames progressive	
			96/1.001 frames progressive	
ST 2036-1	3840 x 2160	4:4:4 (R'G'B')/12-bit, 4:4:4 (Y'C _B C _R)/12-bit	120 frames progressive	
			120/1.001 frames progressive	
			100 frames progressive	
ST 2048-1	4096 x 2160* ²	4:4:4 (R'G'B'* ¹)/12-bit, 4:4:4 (Y'C _B C _R)/12-bit	120 frames progressive	III
			120/1.001 frames progressive	
			100 frames progressive	
			96 frames progressive	
			96/1.001 frames progressive	
ST 2036-1	3840 x 2160	4:2:2 (Y'C _B C _R)/12-bit 4:2:0 (Y'C _B C _R)/12-bit	120 frames progressive	
			120/1.001 frames progressive	
			100 frames progressive	
ST 2048-1	4096 x 2160* ²	4:2:2 (Y'C _B C _R)/12-bit 4:2:0 (Y'C _B C _R)/12-bit 4:2:2:4 (Y'C _B C _R +A)/12-bit	120 frames progressive	IV
			120/1.001 frames progressive	
			100 frames progressive	
			96 frames progressive	
			96/1.001 frames progressive	

Notes:

*1 In this image format R'G'B' indicates either R'G'B' or R'_{FS}G'_{FS}B'_{FS}.

*2 This is the maximum pixel array, the active image may not fill the maximum array.

5.1 Mapping

Figure 5 and Figure 6 illustrate the process for the carriage of 2160-line AFR source image formats in a Quad-link 12G-SDI interface.

Figure 5 illustrates the division of the source image format into four sub images.

Figure 6 illustrates the mapping of sub image one onto 12G-SDI Link 1.

Sub image two is similarly mapped onto 12G_SDI Link 2.

Sub image three is similarly mapped onto 12G_SDI Link 3.

Sub image four is similarly mapped onto 12G_SDI Link 4.

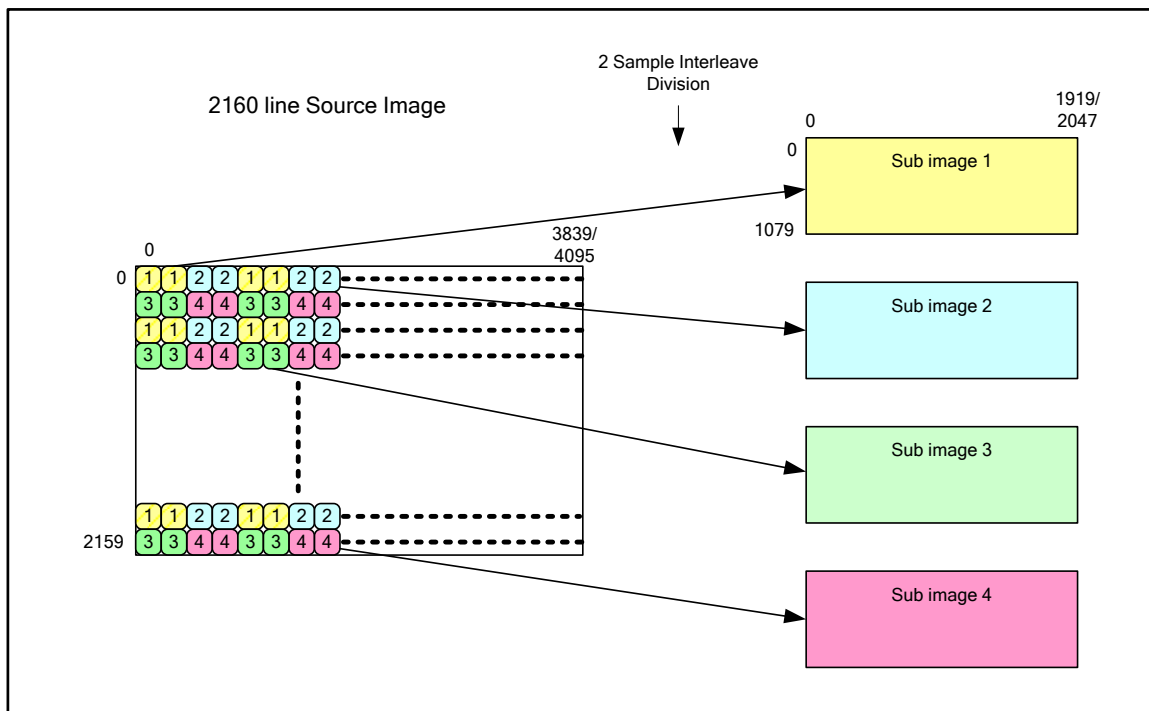

Figure 5 – Division of 2160-line source image into 1080-line sub images

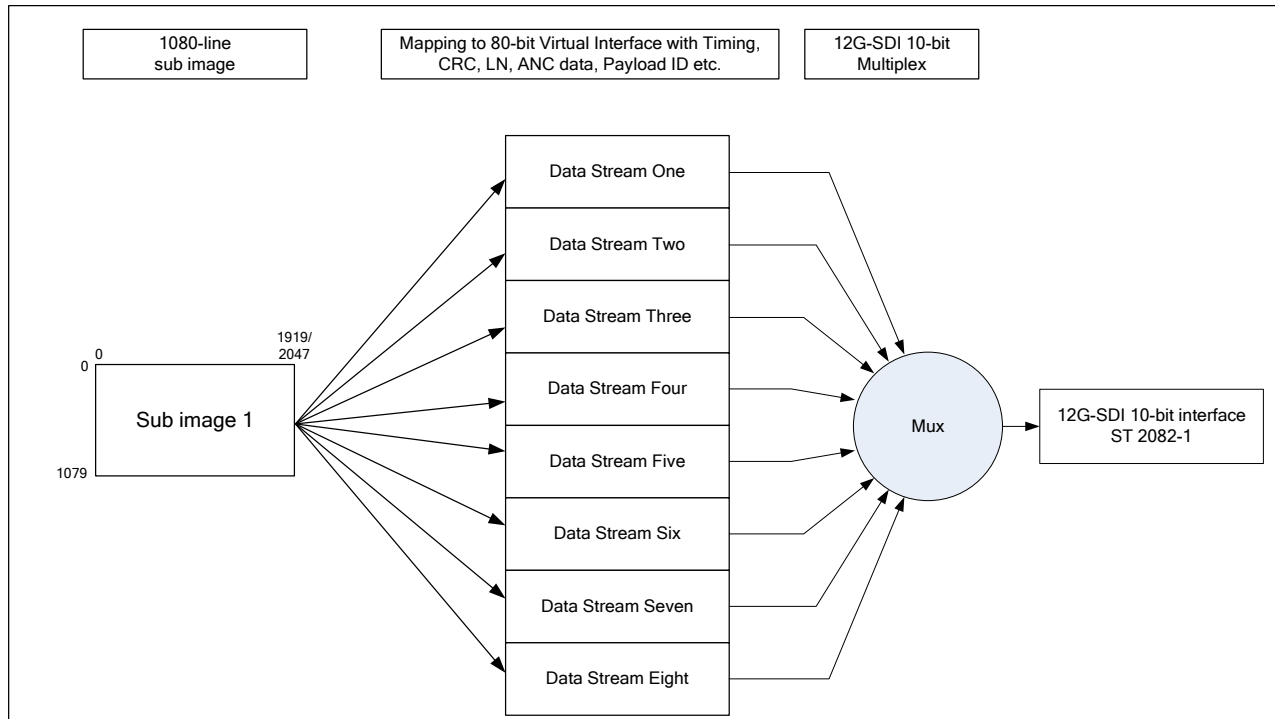

Figure 6 – Carriage of Sub Image 1 on a 12G-SDI interface – overall process

The 2160-line source images shall be divided into four 1080-line sub images in accordance with the 2 sample interleave sub-division method referenced in SMPTE ST 425-5 “2160-line image division into four sub images”.

For a 4:2:0 source image, the 12-bit C'_B and C'_R samples in sub images 3 and 4 shall be set to the value 800h.

5.2 Mapping of 1080-line Sub Images

Each 1080-line sub image shall be mapped to an 80-bit virtual interface consisting of eight data streams. The structure of each data stream shall be as illustrated in Figure 7.

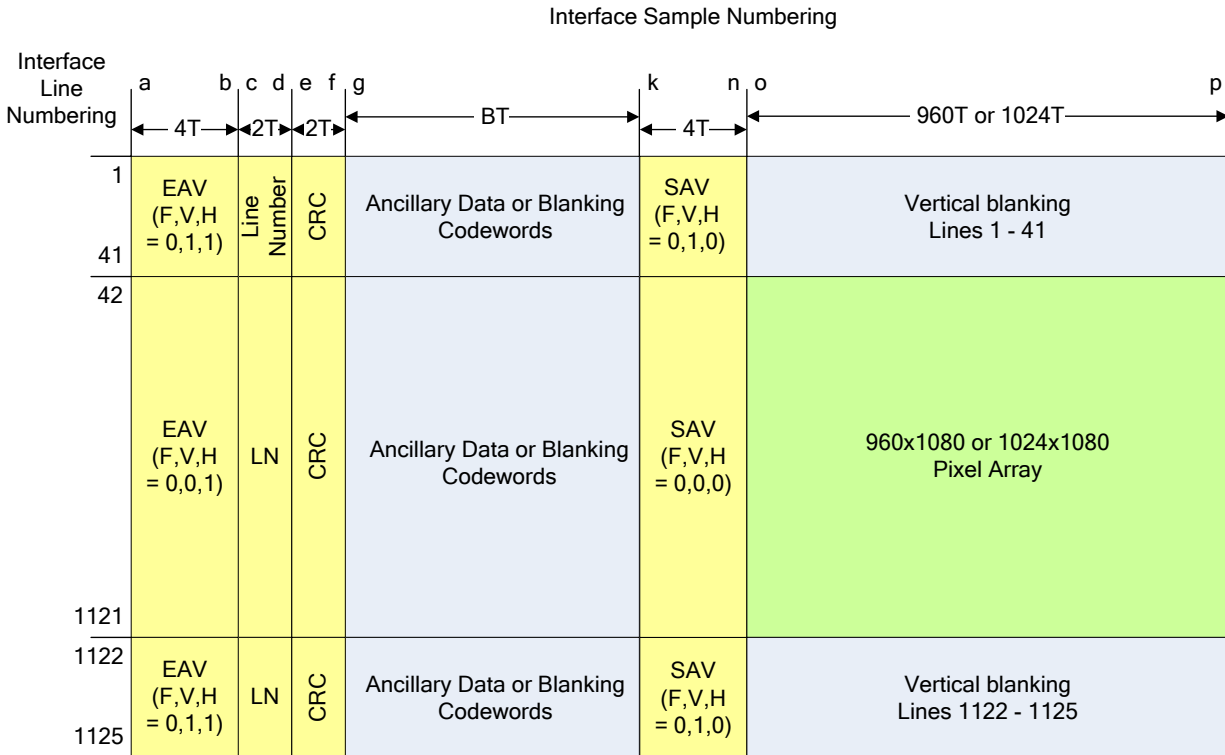

Sub Image Format	a	b	c	d	e	f	g	BT	k	n	o	p
1920 x 1080 / 120	960	963	964	965	966	967	968	128	1096	1099	0	959
1920 x 1080 / 120/1.001	960	963	964	965	966	967	968	128	1096	1099	0	959
1920 x 1080 / 100	960	963	964	965	966	967	968	348	1316	1319	0	959
2048 x 1080 / 120	1024	1027	1028	1029	1030	1031	1032	64	1096	1099	0	1023
2048 x 1080 / 120/1.001	1024	1027	1028	1029	1030	1031	1032	64	1096	1099	0	1023
2048 x 1080 / 100	1024	1027	1028	1029	1030	1031	1032	284	1316	1319	0	1023
2048 x 1080 / 96	1024	1027	1028	1029	1030	1031	1032	339	1371	1374	0	1023
2048 x 1080 / 96/1.001	1024	1027	1028	1029	1030	1031	1032	339	1371	1374	0	1023

Figure 7 – Structure of each data stream for 120 Hz, 120/1.001 Hz, 100 Hz, 96 Hz or 96/1.001 Hz frame rates

5.2.1 Mapping Structure II:

Sub image 1 shall be mapped on to data streams one through eight.

Data stream one shall carry the odd G' samples G'1, G'3, G'5, G'7 ...

Data stream two shall carry the even R' samples R'0, R'2, R'4...

Data stream three shall carry the even G' samples G'0, G'2, G'4, G'6 ...

Data stream four shall carry the even B' samples B'0, B'2, B'4...

Data stream five shall carry the odd A samples A1, A3, A5, A7 ...

Data stream six shall carry the odd R' samples R'1, R'3, R'5...

Data stream seven shall carry the even A samples A0, A2, A4, A6 ...

Data stream eight shall carry the odd B' samples B'1, B'3, B'5...

For the 4:4:4 (Y'C_BC_R) and the 4:4:4:4 (Y'C_BC_R+A)/10-bit images, the sub image shall be mapped as above such that:

The G' samples are replaced with Y' samples,
the B' samples are replaced with C_B samples,
and the R' samples are replaced with C_R samples.

Sub image 2 shall be mapped similarly on to data streams nine through sixteen. Sub image 3 shall be mapped similarly on to data streams seventeen through twenty four. Sub image 4 shall be mapped similarly on to data streams twenty five through thirty two.

The thirty two data streams, data stream one through data stream thirty two, shall be combined into a 320-bit virtual interface.

The 320-bit virtual interface shall have an interface frequency of 148.5 MHz or 148.5/1.001 MHz.

5.2.2 Mapping Structure III

Sub image 1 shall be mapped on to data streams one through eight.

Data stream one shall carry the 10 MSBs of odd G' samples: G'1:2-11, G'3:2-11, G'5:2-11....

Data stream two shall carry the 10 MSBs of even R' samples: R'0:2-11, R'2:2-11, R'4:2-11...

Data stream three shall carry the 10 MSBs of even G' samples: G'0:2-11, G'2:2-11, G'4:2-11...

Data stream four shall carry the 10 MSBs of even B' samples: B'0:2-11, B'2:2-11, B'4:2-11...

Data stream five shall carry the two LSBs of the odd
R', G' and B' samples according to Section 5.2.2.1: R'G'B'1:0-1, R'G'B'3:0-1, R'G'B'5:0-1

Data stream six shall carry the 10 MSBs of odd R' samples: R'1:2-11, R' 3:2-11, R'5:2-11 ...

Data stream seven shall carry the two LSBs of the even
R', G' and B' samples according to Section 5.2.2.1: R'G'B'0:0-1, R'G'B'2:0-1, R'G'B'4:0-1

Data stream eight shall carry the 10 MSBs of odd B' samples: B'1:2-11, B' 3:2-11, B'5:2-11 ...

For the 4:4:4 (Y'C_BC_R) 12-bit images, the sub image shall be mapped as above such that:

The G' samples are replaced with Y' samples,
the B' samples are replaced with C_B samples
and the R' samples are replaced with C_R samples.

Sub image 2 shall be mapped similarly on to data streams nine through sixteen. Sub image 3 shall be mapped similarly on to data streams seventeen through twenty four. Sub image 4 shall be mapped similarly on to data streams twenty five through thirty two.

The thirty two data streams, data stream one through data stream thirty two, shall be combined into a 320-bit virtual interface.

The 320-bit virtual interface shall have an interface frequency of 148.5 MHz or 148.5/1.001 MHz.

5.2.2.1 R'G'B'n:0-1 Data Mapping

Mapping of the least significant 2 bits from R', G' and B' onto data stream five and data stream seven shall be as shown in Table 7.

Table 7 – R'G'B'n:0-1 mapping onto data stream five and data stream seven

Word	Bit Number									
	9	8	7	6	5	4	3	2	1	0
	(MSB)									(LSB)
	B8	EP	G'n:1	G'n:0	B'n:1	B'n:0	R'n:1	R'n:0	Res	Res
Notes:										
1 MSB: most significant bit.										
2 LSB: least significant bit.										
3 B8 is the even parity for B7 through B0.										
4 B9 is the complement of B8.										
5 B0 and B1 are the reserved bits (Reserved bits shall be set to 0 until defined).										

For the 4:4:4 (Y'C_BC_R) 12-bit images, the data shall be mapped as above such that:

The G' samples are replaced with Y' samples,
the B' samples are replaced with C'_B samples
and the R' samples are replaced with C'_R samples.

5.2.3 Mapping Structure IV:

Sub image 1 shall be mapped on to data streams one through eight.

Data stream one shall carry the 10 MSBs of odd Y' samples: Y'1:2-11, Y'3:2-11, Y'5:2-11, Y'7:2-11 ...

Data stream two shall carry the 10 MSBs of even C'_R samples: C'_R0:2-11, C'_R2:2-11, C'_R4:2-11...

Data stream three shall carry the 10 MSBs of even Y' samples: Y'0:2-11, Y'2:2-11, Y'4:2-11, Y'6:2-11 ...

Data stream four shall carry the 10 MSBs of even C'_B samples: C'_B0:2-11, C'_B2:2-11, C'_B4:2-11...

Data stream five shall carry the two LSBs of the odd
Y' samples according to Section 5.2.3.1: Y'1:0-1, Y'3:0-1, Y'5:0-1 ...

Data stream six shall carry the odd A samples: A1, A3, A5, A7....

Data stream seven shall carry the two LSBs of the even
Y', C'_B and C'_R samples according to Section 5.2.3.1: Y'C'_BC'_R0:0-1, Y'C'_BC'_R2:0-1, Y'C'_BC'_R4:0-1...

Data stream eight shall carry the even A samples: A0, A2, A4, A6....

Sub image 2 shall be mapped similarly on to data streams nine through sixteen. Sub image 3 shall be mapped similarly on to data streams seventeen through twenty four. Sub image 4 shall be mapped similarly on to data streams twenty five through thirty two.

The thirty two data streams, data stream one through data stream thirty two, shall be combined into a 320-bit virtual interface.

For a 4:2:0 source image, the 12-bit C'_B and C'_R samples in sub images 3 and 4 shall be set to the value 800h.

The 320-bit virtual interface shall have an interface frequency of 148.5 MHz or 148.5/1.001 MHz.

5.2.3.1 $Y'C'_B C'_R n:0-1, Y'n;0-1$ Data Mapping

Mapping of the least significant 2 bits from the even-numbered samples of Y' , C'_B and C'_R , onto data stream seven shall be as shown in Table 8.

Mapping of the least significant 2 bits from the odd-numbered samples of Y' (only), onto data stream five shall be as shown in Table 9.

Table 8 – $Y'C'_B C'_R n:0-1$ even sample mapping onto data stream seven

		Bit Number									
Word	9	8	7	6	5	4	3	2	1	0	
	(MSB)										(LSB)
	B8	EP	$Y'n:1$	$Y'n:0$	$C'_{Bn}:1$	$C'_{Bn}:0$	$C'_{Rn}:1$	$C'_{Rn}:0$	Res	Res	
Notes:											
1 MSB: most significant bit.											
2 LSB: least significant bit.											
3 B8 is the even parity for B7 through B0.											
4 B9 is the complement of B8.											
5 B1 and B0 are the reserved bits (Reserved bits shall be set to 0 until defined).											

Table 9 – $Y'n:0-1$ odd sample mapping onto data stream five

		Bit Number									
Word	9	8	7	6	5	4	3	2	1	0	
	(MSB)										(LSB)
	B8	EP	$Y'n:1$	$Y'n:0$	Res	Res	Res	Res	Res	Res	Res
Notes:											
1 MSB: most significant bit.											
2 LSB: least significant bit.											
3 B8 is the even parity for B7 through B0.											
4 B9 is the complement of B8.											
5 B5 through B0 are the reserved bits (Reserved bits shall be set to 0 until defined).											

Figure 8 illustrates how sub image 1 of an R'G'B'+A) 10-bit image is mapped onto data streams one through sixteen using mapping structure II. Mapping structure III and mapping structure IV have identical timing and reference, line number and line CRC codes, but different active picture data.

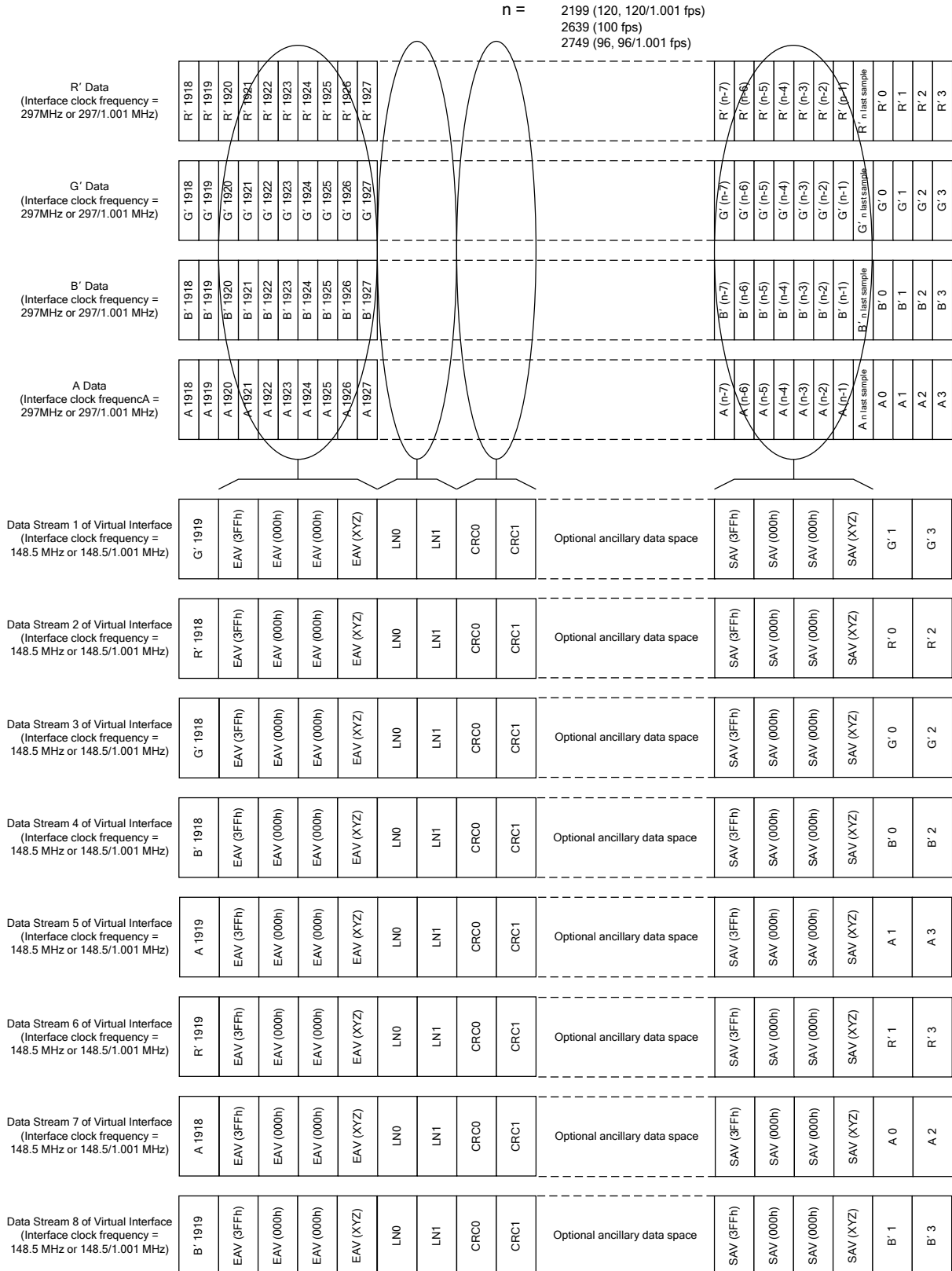

Figure 8 – Mapping Structure II 4:4:4 R'G'B'(A)/10-Bit Signals at 96/1.001, 96, 100, 120/1.001 and 120 Progressive Frames/Sec – Sub image 1

5.3 Timing and Reference Signals

EAV (End of Active Video) and SAV (Start of Active Video) timing references shall be inserted into each data stream of the 320-bit virtual interface on a line-by-line basis as illustrated in Figure 8.

The EAV and SAV sequence, F (field/ frame), V (vertical), H (horizontal) and parity bits P3 through P1 shall be as defined in Table 10 and Table 11.

Table 10 – Bit assignment for timing reference codes

Word	Value	Bit number									
		b9 (MSB)	b8	b7	b6	b5	b4	b3	b2	b1	b0 (LSB)
1	FFFh	1	1	1	1	1	1	1	1	1	1
2	000h	0	0	0	0	0	0	0	0	0	0
3	000h	0	0	0	0	0	0	0	0	0	0
4	XYZ	1	F	V	H	P ₃	P ₂	P ₁	P ₀	0	0

Table 11 – Protection Parity bits for timing reference codes

Bit number	b8	b7	b6	b5	b4	b3	b2
Function	F	V	H	P ₃	P ₂	P ₁	P ₀
Bit pattern 0	0	0	0	0	0	0	0
Bit pattern 1	0	0	1	1	1	0	1
Bit pattern 2	0	1	0	1	0	1	1
Bit pattern 3	0	1	1	0	1	1	0

5.4 Line Numbers

Line numbers shall be inserted into each data stream of the 320-bit virtual interface starting at the first data word (of the virtual interface) following the EAV XYZ word, as illustrated in Figure 8.

Line number data are composed of two words, LN0 and LN1, and shall be as shown in Table 12.

Table 12 – Line Number Data

	B9 (msb)	B8	B7	B6	B5	B4	B3	B2	B1	B0 (lsb)
LN0	$\overline{\text{B8}}$	L6	L5	L4	L3	L2	L1	L0	Res	Res
LN1	$\overline{\text{B8}}$	Res	Res	Res	L10	L9	L8	L7	Res	Res
Notes: 1 L10 : L0 = line number in binary code. 2 Res = reserved, set to "0" and shall be ignored by receivers.										

5.5 Line CRC Codes

CRC (Cyclic Redundancy Check) codes shall be inserted into each data stream of the 320-bit virtual interface starting at the first data word (of the virtual interface) following the final word of the line number – LN1, as illustrated in Figure 8.

The CRC code words are used to detect errors in the active digital line, the EAV timing reference signal and line number words that follow it. The error detection code consists of two words determined by the polynomial generator equation:

$$\text{CRC}(X) = X^{18} + X^5 + X^4 + 1$$

The initial value of the CRC shall be zero. The calculation shall start at the first active line word of the interface and shall end at the final word of the line number – LN1.

Independent CRC codes shall be produced for each data stream of the 160-bit virtual interface.

The two words of the CRC code shall be as shown in Table 13.

Table 13 – CRC Data

	B9(msb)	B8	B7	B6	B5	B4	B3	B2	B1	B0(lsb)
CR0	$\overline{\text{B8}}$	CRC8	CRC7	CRC6	CRC5	CRC4	CRC3	CRC2	CRC1	CRC0
CR1	$\overline{\text{B8}}$	CRC17	CRC16	CRC15	CRC14	CRC13	CRC12	CRC11	CRC10	CRC9

5.6 HANC and VANC Space of Data Streams

When present, ancillary data packets shall be mapped into the HANC or the VANC spaces of each data stream and shall be in accordance with SMPTE ST 291.

The HANC and VANC spaces for each data stream are defined in Figure 7 of Section 5.2.

Unless otherwise stated, the ancillary data shall be preferentially mapped into data stream one first and any remaining data shall then be mapped onto data stream three; then into data stream five, data stream seven and so on up to data stream thirty one. Data space requirements and locations for each data service are defined by their respective application documents. In some cases it is required by specific applications that ancillary data be mapped into all thirty two data streams (e.g. Payload ID.)

Informative Annex A provides information about the amount of HANC and VANC data space available in this operating mode.

5.7 Audio Data

When present, audio data shall be mapped into the HANC space of data streams one through thirty two and shall be in conformance with SMPTE ST 299-1 and SMPTE ST 299-2.

Audio control packets shall be mapped into the odd numbered data streams.

Audio data packets shall be mapped into the even numbered data streams.

Audio control and data packets shall be mapped into the data stream pair one/two first and any remaining data shall then be mapped onto data stream pair three/four; then into data stream pair five /six, and so on up to data stream pair thirty one/thirty two.

The audio clock phase data as defined in the section “CLK (audio clock phase data)” of SMPTE ST 299-1 shall be calculated at the data stream clock frequency of 148.5 MHz.

Note: Some audio applications use non-PCM audio data. These may require the use of a marker as defined in SMPTE ST 2051 (see Bibliography) to indicate which frame contains the SDI switching point for the non-PCM data payload.

5.7.1 Number of Audio Channels

Informative Note:

1080p images at 96, 100 and 120 fps have horizontal line rates of 108 kHz, 112.5 kHz and 135 kHz respectively.

As SMPTE ST299-1 states that an audio sample should be placed in the next available line, and calculates the phase word from the start of the line, it is only possible to embed audio samples in one line every 20.833 us on average (i.e. at 48 kHz). This means that the majority of the lines are not available for audio embedding, and the number of audio channels that can be transported is significantly less than appears from a simple calculation of the total HANC space.

Informative Note ends

Up to 256 audio channels sampled at 32 kHz, 44.1 kHz or 48 kHz may be mapped into data streams one through thirty two of the 320-bit virtual interface. At 96 kHz sampling, up to 128 audio channels may be mapped into the virtual interface.

The maximum number of audio channels that can be mapped into the available ancillary data space of each data stream pair varies in accordance with the video format and the video frame rate. Table 14 shows the overall capacity of the 320-bit virtual interface.

Table 14 – Number of Audio Channels supported Source Image Format, Frame Rate and Audio Sampling Rate

Source Image Format	Frame Rate	Maximum number of audio channels at 32 kHz, 44.1 kHz or 48 kHz sampling	Maximum number of audio channels at 96 kHz sampling
3840x2160	100 and 120 Progressive	Up to 256 channels	Up to 128 channels
4096x2160	96 and 100 Progressive	Up to 256 channels	Up to 128 channels
	120 Progressive	Up to 128 channels	Up to 64 channels

5.7.1.1 Carriage of up to 256 Channels of Audio at up to 48 kHz Sampling

For audio at up to 48 kHz sampling embedded into 4096 x 2160 image formats at a frame rate of 120, the audio data and control packets for the first 8 channels shall be mapped into data stream pair one/two in conformance with SMPTE ST 299-1 (audio groups 1 to 4).

The audio data and control packets for the second 8 channels shall be mapped into data stream pair three/four in conformance with SMPTE ST 299-1 (audio groups 1 to 4).

The audio data and control packets for the third 8 channels shall be mapped into data stream pair five/ six in conformance with SMPTE ST 299-1 (audio groups 1 to 4).

The audio data and control packets for the fourth 8 channels shall be mapped into data stream pair seven/eight in conformance with SMPTE ST 299-1 (audio groups 1 to 4).

The audio data and control packets for the fifth 8 channels shall be mapped into data stream pair nine/ten in conformance with SMPTE ST 299-1 (audio groups 1 to 4).

Successive sets of 8 channels shall be mapped into successive data stream pairs, up to:

The audio data and control packets for the fifteenth 8 channels shall be mapped into data stream pair twenty nine/thirty in conformance with SMPTE ST 299-1 (audio groups 1 to 4).

The audio data and control packets for the sixteenth 8 channels shall be mapped into data stream pair thirty one/thirty two in conformance with SMPTE ST 299-1 (audio groups 1 to 4).

For audio at up to 48 kHz sampling embedded into all other 2160-line image formats shown in Table 14, the audio data and control packets and for the first 16 channels shall be mapped into data stream pair one/two in conformance with SMPTE ST 299-1 (audio groups 1 to 4).

The audio data and control packets and audio data and control packets for the second 16 channels shall be mapped into data stream pair three/four in conformance with SMPTE ST 299-1 (audio groups 1 to 4).

The audio data and control packets for the third 16 channels shall be mapped into data stream pair five/six in conformance with SMPTE ST 299-1 (audio groups 1 to 4).

The audio data and control packets for the fourth 16 channels shall be mapped into data stream pair seven/eight in conformance with SMPTE ST 299-1 (audio groups 1 to 4).

Successive sets of 16 channels shall be mapped into successive data stream pairs, up to:

The audio data and control packets for the sixteenth 16 channels shall be mapped into data stream pair thirty one/thirty two in conformance with SMPTE ST 299-1 (audio groups 1 to 4).

5.7.1.2 Carriage of up to 128 Channels of Audio at 96 kHz Sampling

For audio at 96 kHz sampling embedded into 4096 x 2160 image formats at frame rates of 120, the audio data and control packets for the first 4 channels shall be mapped into data stream pair one and two in conformance with SMPTE ST 299-1 (audio groups 1 to 4).

The audio data and control packets for the second 4 channels shall be mapped into data stream pair three and four in conformance with SMPTE ST 299-1 (audio groups 1 to 4).

The audio data and control packets for the third 4 channels shall be mapped into data stream pair five and six in conformance with SMPTE ST 299-1 (audio groups 1 to 4).

The audio data and control packets for the fourth 4 channels shall be mapped into data stream pair seven and eight in conformance with SMPTE ST 299-1 (audio groups 1 to 4).

Successive sets of 4 channels shall be mapped into successive data stream pairs, up to:

The audio data and control packets for the sixteenth 4 channels shall be mapped into data stream pair thirty one/thirty two in conformance with SMPTE ST 299-1 (audio groups 1 to 4).

For audio at 96 kHz sampling, embedded into all other 2160-line image formats shown in Table 14, the audio data and control packets for the first 8 channels shall be mapped into data stream pair one and two in conformance with SMPTE ST 299-1 (audio groups 1 to 4).

The audio data and control packets for the second 8 channels shall be mapped into data stream pair three and four in conformance with SMPTE ST 299-1 (audio groups 1 to 4).

The audio data and control packets for the third 8 channels shall be mapped into data stream pair five and six in conformance with SMPTE ST 299-1 (audio groups 1 to 4).

The audio data and control packets for the fourth 8 channels shall be mapped into data stream pair seven and eight in conformance with SMPTE ST 299-1 (audio groups 1 to 4).

Successive sets of 8 channels shall be mapped into successive data stream pairs, up to:

The audio data and control packets for the sixteenth 8 channels shall be mapped into data stream pair thirty one/thirty two in conformance with SMPTE ST 299-1 (audio groups 1 to 4).

5.7.2 Audio Copy

As an alternative to the mapping of the maximum number of unique audio channels described above, blocks of audio channels may be copied within the interface. This may be done in order for Links 2, 3 and 4 to carry a copy of the audio on Link 1.

Note: Audio copy reduces the number of channels that can be transported by the interface.

If audio is copied:

Data streams one through eight shall always carry original audio.

Data streams nine through sixteen may also carry original audio.

Data streams seventeen through thirty two may carry copied audio from data streams one through sixteen.

Data streams nine through sixteen may carry copied audio from data streams one through eight. In this case data streams seventeen through twenty four, and data streams twenty five through thirty two shall also carry the same copied audio.

The audio copy status of each data stream shall be signaled in that data stream's PID as described in Section 5.9.

5.8 Time Code Data

When present the data format of ATC packets shall be in conformance with SMPTE ST 12-3.

When present the packet or packets shall be mapped into the HANC or VANC space of data stream one. The preferred location should be as indicated in Table 15.

Table 15 – Preferred locations for time code insertion into data streams

Payload Type	Location
ATC_HFRTC	HANC, Line 11
ATC_HFRTC *	HANC, Line 12
ATC_HFRTC *	HANC, Line 13
ATC_HFRTC *	HANC, Line 14

Note: * Transmissions of multiple ancillary time code packets with different instance identifications (bitstream numbers) per video frame are permissible under the provisions of SMPTE ST 12-3. The default bitstream number is zero. Lines 12, 13 and 14 are for use when necessary based on the number of bitstreams

The ATC_HFRTC packet with bitstream number zero shall be preferentially mapped onto line 11 first and any remaining bitstreams shall then be mapped onto the same line. If there is insufficient space remaining on the same line, remaining bitstreams shall be mapped onto line 12, then onto line 13, then onto line 14.

The time code may also be mapped into data stream three, data stream five, data stream seven, and any or all odd-numbered data streams up to data stream fifteen, in which case the corresponding Time Address values shall be identical.

5.9 Payload Identifier

Table 16 shows the payload identifier definitions for 2160-line AFR Video Payloads. As stated in SMPTE ST 352, the payload identifier consists of 4 bytes where each byte has a separate significance. The first byte of the payload identifier has the highest significance and subsequent bytes define lower order video and ancillary payload information.

The horizontal placement of the packet should be immediately following the last CRC code word (CR1) of the line(s) specified in SMPTE ST 352 for 1125-line systems.

Note: The line numbers defined in SMPTE ST 352 for the placement of the payload identifier packet in 1125-line systems avoid those lines used by SMPTE ST 299-1 and SMPTE ST 299-2 for the carriage of digital audio control packets and extended audio control packets, respectively.

Table 16 – Payload Identifier Definitions for 2160-line AFR Video Payload for Mapping on a Quad-link 12Gb/s (nominal) Serial Interface

Bits	Byte 1	Byte 2	Byte 3	Byte 4
Bit 7	1	Progressive transport (1)	Aspect Ratio 16:9 (1) or Unknown (0)	Link assignment 12G-SDI Link 1 (0h) 12G-SDI Link 2 (1h) 12G-SDI Link 3 (2h) 12G-SDI Link 4 (3h)
Bit 6	1	Progressive picture (1)	Sub Image horizontal sampling 1920 (0) or 2048 (1)	
Bit 5	0	Reserved (0)	Colorimetry	
Bit 4	1	Reserved (0)	Rec 709* ¹ (0h) Color VANC Packet (1h) UHDTV* ² (2h) Unknown (3h)	Reserved (0)
Bit 3	0	Picture rate (See Table 4)	Sampling structure (See Table 5)	Reserved (0)
Bit 2	0			Audio copy status: Audio in this data stream carries additional channels or audio not present (0) Audio in this data stream is copied (1)
Bit 1	1			Bit depth 10-bit (1h) 12-bit (2h) Other values are Reserved
Bit 0	1			

Notes:

*1 Rec 709 indicates ITU-R recommendation BT.709 colorimetry and is equivalent to SMPTE ST 2036-1 Conventional System Colorimetry.

*2 UHDTV indicates SMPTE ST 2036-1 UHDTV colorimetry and is equivalent to ITU-R recommendation BT.2020 colorimetry.

5.9.1 Byte 1 - Digital Interface and Payload Identification

Byte 1 of the payload identifier identifies the video payload and the digital interface and shall be as defined below.

Byte 1 shall be set to [D3h] for 2160-line image formats listed in Table 6 transported via quad-link 12G-SDI.

5.9.2 Byte 2 – Picture Rate and Scanning Method

Byte 2 of the payload identifier shall be used to identify the picture and transport scanning methods and the picture rate.

Bit b7 shall be set to 1 (progressive transport).

Bit b6 shall be set to 1 (progressive picture).

Bit b5 shall be set to 0 (reserved).

Bit b4 shall be set to 0 (reserved).

Bits b3 to b0 shall be used to identify the picture rate in Hz according to Table 4 and shall only use the values as permitted for image formats in Table 6.

5.9.3 Byte 3 – Sampling Structure, Aspect Ratio and Horizontal Size

Byte 3 of the payload identifier shall be used to identify the aspect ratio, horizontal pixel array size, and sampling structure of the video payload.

Bit b7 shall be used to identify the aspect ratio such that:

b7 = 0h shall identify unknown aspect ratio

b7 = 1h shall identify a 16:9 aspect ratio

Bit b6 shall be used to identify the number of active Luma/R'G'B' samples for the sub image such that:

b6 = 0h shall identify 1920 active Luma/R'G'B' samples

b6 = 1h shall identify 2048 active Luma/R'G'B' samples

Bits b5 and b4 shall identify the colorimetry for the image formats identified in Table 6 such that:

b5:b4 = 0h shall identify Rec 709 colorimetry

b5:b4 = 1h shall identify that the colorimetry is defined in the Color VANC packet referenced in SMPTE ST 2048-2

b5:b4 = 2h shall identify UHDTV colorimetry

b5:b4 = 3h shall identify unknown colorimetry

Bits b3 to b0 shall be used to identify the sampling structure in accordance with Table 5 and shall only use the values as permitted for image formats in Table 6.

5.9.4 Byte 4 – Link Identification, Audio Copy Status and Quantization Bit Depth

Byte 4 of the payload identifier shall be used to the link assignment, the audio copy status and the bit depth of the sample quantization.

Bits b7 to b5 shall be used to identify Link assignment and set to:

- b7:b5 = 0h shall identify 12G-SDI Link 1
- b7:b5 = 1h shall identify 12G-SDI Link 2
- b7:b5 = 2h shall identify 12G-SDI Link 3
- b7:b5 = 3h shall identify 12G-SDI Link 4

Bit b4 shall be reserved and set to 0

Bit b3 shall be reserved and set to 0

For data streams one through eight bit b2 shall be set to 0 (reserved)

For data streams nine through thirty two bit b2 shall be used to identify whether audio data in this data stream is copied:

- b2 = 0 shall identify that all audio if present in this data stream carries additional channels
- b2 = 1 shall identify that audio if present in this data stream is copied

Bits b1 to b0 shall be used to identify the bit depth of the sample quantization such that:

- b1:b0 = 1h shall identify quantization using 10 bits per sample
- b1:b0 = 2h shall identify quantization using 12 bits per sample
- Other values shall be reserved.

5.10 Blanking

HANC and VANC space with no ancillary data packets or audio data packets shall contain data words that represent video black level for the video structure being carried.

5.10.1 Blanking Values (Informative)

For Mapping Structure II R'G'B'+A) 10-bit formats all words of all data streams take the value 040h

For Mapping Structure II Y'C_BC_R(+A) 10-bit formats all words of all odd numbered data streams take the value 040h, and all words of all even numbered data streams take the value 200h

For Mapping Structure III R'G'B' 12-bit formats all words of data streams five, seven, thirteen, fifteen, twenty one, twenty three, twenty nine and thirty one take the value 200h. All words in all other data streams take the value 040h.

For Mapping Structure III Y'C_BC_R 12-bit formats all words of data stream one, three, nine, eleven, seventeen, nineteen, twenty five and twenty seven take the value 040h. All words in all other data streams take the value 200h.

For Mapping Structure IV Y'C_BC_R+A 4:2:2:4 12-bit formats all words of data stream one, three, six, eight, nine, eleven, fourteen, sixteen, seventeen, nineteen, twenty two, twenty four, twenty five, twenty seven, thirty and thirty two take the value 040h. All words in all other data streams take the value 200h.

5.11 Multiplex

The 320-bit virtual interface shall then be multiplexed onto four Type 1 12G-SDI 10-bit interfaces according to Section 6.

5.12 Levels of Operation (Informative)

To define the level of support for SMPTE ST 2082-12 Mode 2, manufacturers are encouraged to indicate in publications which mapping format is supported. For example:

SMPTE ST 2082-12 MODE 2 – 2160-line AFR Source image formats and ancillary data into a Quad-link 12 Gb/s [nominal] SDI bit-serial interface

Manufacturers are also encouraged to indicate in publications supported audio and video formats.

6 Quad-link 12G-SDI 10-bit Multiplex

Prior to serialization Data streams one through thirty two of the 320-bit virtual interface shall be multiplexed word-by-word into four 12G-SDI 10-bit interfaces.

The first 10-bit interface shall consist of a word multiplex of data streams one through eight, in the order data stream eight, data stream four, data stream six, data stream two, data stream seven, data stream three, data stream five, data stream one...This 10-bit interface shall then be serialized according to SMPTE ST 2082-1 to create 12G-SDI Link 1.

The second 10-bit interface shall consist of a word multiplex of data streams nine through sixteen, in the order data stream sixteen, data stream twelve, data stream fourteen, data stream ten, data stream fifteen, data stream eleven, data stream thirteen, data stream nine... This 10-bit interface shall then be serialized according to SMPTE ST 2082-1 to create 12G-SDI Link 2.

The third 10-bit interface shall consist of a word multiplex of data streams seventeen through twenty four, in the order data stream twenty four, data stream twenty, data stream twenty two, data stream eighteen, data stream twenty three, data stream nineteen, data stream twenty one, data stream seventeen...This 10-bit interface shall then be serialized according to SMPTE ST 2082-1 to create 12G-SDI Link 3.

The fourth 10-bit interface shall consist of a word multiplex of data streams twenty five through thirty two, in the order data stream thirty two, data stream twenty eight, data stream thirty, data stream twenty six, data stream thirty one, data stream twenty seven, data stream twenty nine, data stream twenty five... This 10-bit interface shall then be serialized according to SMPTE ST 2082-1 to create 12G-SDI Link 4.

Each of the four 10-bit parallel interfaces so produced shall have an interface frequency of 1188 MHz or 1188/1.001MHz as shown in Figure 9.

7 12G-SDI Link 1 / 12G-SDI Link 2 / 12G-SDI Link 3 / 12G-SDI Link 4 Interface Timing

The timing difference between the EAV / SAV of any pair of 12G-SDI Link 1, 12G-SDI Link 2, 12G SDI Link 3 and 12G-SDI Link 4 shall not exceed 250ns at the serial output of source equipment. This difference should be taken into consideration when designing systems and destination equipment input stages.

Annex A Ancillary Data Capacity of the Quad-link 12G-SDI Interface (Informative)

The ancillary data space available in serial digital interface transports is approximately equivalent to horizontal interval space and vertical interval space for the video format being transported. In the case of images transported on the interface specified in this standard, it is dependent on the horizontal interval space and vertical interval space for each of the data streams being carried on the interface, multiplied by the number of data streams.

SMPTE RP 291-2 provides information on the size of the ancillary data space in a SMPTE ST 425-1 and SMPTE ST 292-1 interface.

For Mode 1 4320-line source image formats specified in this standard, the available HANC and VANC data space on the interface is 16 times the HANC and VANC data space available (as shown in the tables of SMPTE RP 291-2) on a SMPTE ST 425-1 interface carrying the corresponding sub-image.

For Mode 2 2160-line source image formats specified in this standard, the available HANC and VANC data space on each of the thirty two data streams of the interface is defined in Section 5.2 of this document.

SMPTE RP 291-2 also provides a method of calculating the available ancillary data space on any interface. These calculations provide the reader with the underlying formulas used to calculate the numbers in the tables, as well as providing a mechanism to calculate the space for interfaces not covered explicitly by SMPTE RP 291-2.

Annex B Bibliography (Informative)

Note: All references in this document to other SMPTE documents use the current numbering style (e.g. SMPTE ST 274:2008) although, during a transitional phase, the document as published (printed or PDF) may bear an older designation (such as SMPTE 274M-2008). Documents with the same root number (e.g. 274) and publication year (e.g. 2008) are functionally identical.

SMPTE ST 274:2008, Television — 1920 x 1080 Image Sample Structure, Digital Representation and Digital Timing Reference Sequences for Multiple Picture Rates

SMPTE ST 292-1:2012, 1.5 Gb/s Signal/Data Serial Interface

SMPTE ST 425-1:2014, Source Image Format and Ancillary Data Mapping for the 3 Gb/s Serial Interface

SMPTE ST 425-3:2015, Image Format and Ancillary Data Mapping for the Dual Link 3 Gb/s Serial Interface

SMPTE ST 2051:2014, Two-Frame Marker for 48/(1.001)-Hz, 50-Hz and 60/(1.001)-Hz Progressive Digital Video Signals on 1.5 Gb/s and 3 Gb/s Interfaces

SMPTE ST 2082-1:2015, 12G-SDI – Signal/Data Serial Interface — Electrical

Recommendation ITU-R BT.709-5, Parameter Values for the HDTV Standards for Production and International Programme Exchange

Recommendation ITU-R BT.2020, Parameter Values for Ultra-High Definition Television Systems for Production and International Programme Exchange