

# SMPTE STANDARD

## Mapping Metadata-Guided Audio (MGA) signals into the MXF Constrained Generic Container



Page 1 of 17 pages

<b>Table of Contents</b>		<b>Page</b>
<b>Foreword</b>	.....	<b>3</b>
<b>Introduction</b>	.....	<b>4</b>
<b>1</b>	<b>Scope</b> .....	<b>4</b>
<b>2</b>	<b>Normative References</b> .....	<b>4</b>
<b>3</b>	<b>Terms and Definitions</b> .....	<b>5</b>
<b>4</b>	<b>MGA mappings</b> .....	<b>5</b>
4.1	General .....	5
4.2	Application in the MXF Generic Container.....	5
4.3	MGA Frame.....	5
4.3.1	General.....	5
4.3.2	Audio Essence.....	7
4.3.3	Audio Metadata .....	8
4.3.4	Fill Data.....	8
4.4	MGA Signal .....	8
<b>5</b>	<b>Key-length-value coding</b> .....	<b>9</b>
5.1	MGA Sound Element Key .....	9
5.2	MGA Sound Element Length .....	9
5.3	MGA Sound Element Value .....	9
5.3.1	Frame-wrapped .....	9
5.3.2	Clip-wrapped .....	9
<b>6</b>	<b>SMPTE Label Values</b> .....	<b>10</b>
6.1	Essence Container Label.....	10
6.2	Sound Essence Coding Label.....	10
<b>7</b>	<b>Application Issues</b> .....	<b>10</b>
7.1	Index Table Usage.....	10

**8**        **Essence Descriptors** ..... **11**

    8.1        General ..... 11

    8.2        MGA Sound Essence Descriptor ..... 11

    8.3        MGA Audio Metadata SubDescriptor ..... 12

**9**        **Audio Labeling** ..... **13**

    9.1        General ..... 13

    9.2        MGA Soundfield Group Label SubDescriptor ..... 13

    9.3        Usage of the GroupOfSoundfieldGroupsLabelSubDescriptor ..... 15

**Annex A (Informative) Descriptor Object Model** ..... **16**

**Bibliography (Informative)** ..... **17**

## **Foreword**

SMPTE (the Society of Motion Picture and Television Engineers) is an internationally-recognized standards developing organization. Headquartered and incorporated in the United States of America, SMPTE has members in over 80 countries on six continents. SMPTE's Engineering Documents, including Standards, Recommended Practices, and Engineering Guidelines, are prepared by SMPTE's Technology Committees. Participation in these Committees is open to all with a bona fide interest in their work. SMPTE cooperates closely with other standards-developing organizations, including ISO, IEC and ITU.

SMPTE Engineering Documents are drafted in accordance with the rules given in its Standards Operations Manual. This SMPTE Engineering Document was prepared by Technology Committee 31FS File Formats and Systems.

Normative text is text that describes elements of the design that are indispensable or contains the conformance language keywords: "shall", "should", or "may". Informative text is text that is potentially helpful to the user, but not indispensable, and can be removed, changed, or added editorially without affecting interoperability. Informative text does not contain any conformance keywords.

All text in this document is, by default, normative, except: the Introduction, any section explicitly labeled as "Informative" or individual paragraphs that start with "Note:"

The keywords "shall" and "shall not" indicate requirements strictly to be followed in order to conform to the document and from which no deviation is permitted.

The keywords "should" and "should not" indicate that, among several possibilities, one is recommended as particularly suitable, without mentioning or excluding others; or that a certain course of action is preferred but not necessarily required; or that (in the negative form) a certain possibility or course of action is deprecated but not prohibited.

The keywords "may" and "need not" indicate courses of action permissible within the limits of the document.

The keyword "reserved" indicates a provision that is not defined at this time, shall not be used, and may be defined in the future. The keyword "forbidden" indicates "reserved" and in addition indicates that the provision will never be defined in the future.

A conformant implementation according to this document is one that includes all mandatory provisions ("shall") and, if implemented, all recommended provisions ("should") as described. A conformant implementation need not implement optional provisions ("may") and need not implement them as described.

Unless otherwise specified, the order of precedence of the types of normative information in this document shall be as follows: Normative prose shall be the authoritative definition; Tables shall be next; then formal languages; then figures; and then any other language forms.

## Introduction

This section is entirely informative and does not form an integral part of this Engineering Document.

Metadata-Guided Audio (MGA) signals, as covered by this specification, comprise of Audio Essence and associated Audio Metadata.

This document specifies the mapping of an MGA Signal into the Constrained MXF Generic Container, as specified in SMPTE ST 379-2, in both frame-wrapped and clip-wrapped forms. This standard is intended to be metadata format-agnostic, capable of supporting any Audio Metadata format that is relevant for the application. Mapping requirements for specific Audio Metadata formats are out of scope of this standard.

At the time of publication, no notice had been received by SMPTE claiming patent rights essential to the implementation of this Engineering Document. However, attention is drawn to the possibility that some of the elements of this document may be the subject of patent rights. SMPTE shall not be held responsible for identifying any or all such patent rights.

## 1 Scope

This document specifies the mapping of Metadata-Guided Audio (MGA) signals into the Constrained MXF Generic Container, as specified in SMPTE ST 379-2. Metadata-Guided Audio (MGA) signals are used e.g. in Next Generation Audio (NGA) applications and comprise of Audio Essence and associated Audio Metadata. This standard specifies the mapping of MGA Signals as either frame-wrapped or clip-wrapped. This standard defines the KLV coding, the essence container and compression label values and the essence descriptor.

## 2 Normative References

The following standards contain provisions that, through reference in this text, constitute provisions of this standard. Dated references require that the specific edition cited shall be used as the reference. Undated citations refer to the edition of the referenced document (including any amendments) current at the date of publication of this document. All standards are subject to revision, and users of this engineering document are encouraged to investigate the possibility of applying the most recent edition of any undated reference.

SMPTE ST 377-1:2019, Material Exchange Format (MXF) — File Format Specification

SMPTE ST 377-4:2021, MXF Multichannel Audio Labeling Framework

SMPTE ST 377-41:2021, MXF Multichannel Audio Controlled Vocabulary

SMPTE ST 377-42:2021, MCA Label Controlled Vocabulary

SMPTE ST 379-2:2010, Television — Material Exchange Format (MXF) — MXF Constrained Generic Container

SMPTE ST 382:2007, Material Exchange Format — Mapping AES3 and Broadcast Wave Audio into the MXF Generic Container

SMPTE ST 400:2012, SMPTE Labels Structure

SMPTE ST 2109:2019, Format for Non-PCM Audio and Data in AES3 — Audio Metadata

### 3 Terms and Definitions

For the purposes of this document, the terms and definitions given in SMPTE ST 377-1 and the following apply:

#### 3.1. Metadata-Guided Audio (MGA) signal

data stream comprised of Audio Essence and associated Audio Metadata.

#### 3.2. MGA Frame

data structure comprised of one Edit Unit of Audio Essence and associated Audio Metadata.

### 4 MGA mappings

#### 4.1 General

The MXF Generic Container (GC) is fully described in SMPTE ST 379-2.

This standard specifies the mapping of MGA Signals into the MGA Sound Element. The MGA Sound Element may be used in the sound item of the MXF GC. The MGA Sound Element shall contain either individual MGA Frames using frame-wrapping or a sequence of MGA Frames using clip-wrapping.

An MGA Frame shall comprise of Audio Essence and associated Audio Metadata for the duration of one Edit Unit, as defined in SMPTE ST 377-1.

**NOTE** The corresponding Edit Rate typically matches the desired editing rate of the image data for video applications.

This standard specifies the key, the length, and the value fields of the MGA Sound Element. This standard also defines the essence container label, the sound essence coding label and the essence descriptor.

#### 4.2 Application in the MXF Generic Container

This mapping shall use the Constrained MXF Generic Container in either the frame-based wrapping or clip-based wrapping mode, as specified in SMPTE ST 379-2.

The following wrapping modes are defined:

- Frame-based wrapping
- Clip-based wrapping

These are described in Section 5.3.

#### 4.3 MGA Frame

##### 4.3.1 General

The Data Structure, as defined in Table 1, shall be used for frame-wrapping and clip-wrapping.

For identifying Audio Essence, Audio Metadata and fill sections, an Index and an Identifier shall be used. The values of the Length items shall be identical to the number of bytes of the Audio Essence Data, Audio Metadata and Fill Data items, respectively.

An MGA Frame shall contain exactly one Audio Essence section, one or more Audio Metadata sections, and zero or one fill section. The order of sections shall be as defined in Table 1. An Audio Essence section comprises of Index, Identifier, Length and Audio Essence Data. An Audio Metadata section comprises of Index, Identifier, Length and Audio Metadata. A fill section comprises of Index, Identifier, Length and Fill Data.

Table 1 — MGA Frame

Item Name	Type	Length	Required?	Value	Note
Section Count	UInt8	1	Req.	Total count of sections in the MGA Frame	2 or higher
<i>Audio Essence section (exactly one occurrence required)</i>					
Index	UInt8	1	Req.	0x00	0x00 indicates Audio Essence
Identifier	UInt8	1	Req.	0x00	0x00 indicates Audio Essence
Length	UInt32	4	Req.		
Audio Essence Data	UInt8	Var.	Req.	Sequence of uncompressed audio samples (see 4.3.2)	
<i>Audio Metadata section (one or more occurrences)</i>					
Index	UInt8	1	Req.	Index, beginning with 0x01 for the first metadata section. Shall be incremented by 0x01 for each additional metadata section. The maximum value shall be 0xfe.	0x01..0xfe indicates Audio Metadata
Identifier	UInt8	1	Req.	See 4.3.3	
Length	UInt32	4	Req.		A value of zero indicates no Audio Metadata is present.
Audio Metadata	UInt8	Var.	Req.	See 4.3.3	

**SMPTE ST 2127-1:2022**

Item Name	Type	Length	Required?	Value	Note
<i>Fill section (zero or one occurrence)</i>					
Index	UInt8	1	Req.	0xff	
Identifier	UInt8	1	Req.	0xff	
Length	UInt32	4	Req.		
Fill Data	UInt8	Var.	Req.	Bytes with a value of zero	

NOTE Per SMPTE ST 377-1:2019, Section 6.4.2, all multi-byte values in any KLV packet are coded as big-endian (most significant byte first)

**4.3.2 Audio Essence**

Audio Essence Data shall be encoded as defined in SMPTE ST 382.

NOTE The encoding of the Audio Essence Data is indicated by the Sound Essence Coding Label, as specified in Section 6.2

### 4.3.3 Audio Metadata

Identifier values and Audio Metadata shall be according to Table 2.

**Table 2 — Audio Metadata formats for MGA Frames**

Identifier Value (see Table 1)	Audio Metadata format	NOTE
0x01	A single Audio Metadata Pack, as defined in SMPTE ST 2109	A single complete Audio Metadata Pack, beginning with the Audio Metadata Pack Key
0x02	A single Audio Metadata Payload, as defined in SMPTE ST 2109	A single Audio Metadata Payload beginning with the Audio Metadata Payload Tag.  Legal values of the Audio Metadata Payload Tag and the associated ULs are listed in the SMPTE ST 2109 Administrative Register
0x03	UL-defined metadata, consisting of a SMPTE-registered Label, as defined in SMPTE ST 400, followed by payload. The definition of allowed ULs and associated payloads is beyond the scope of this standard.	

NOTE 1 Audio Metadata Payload Tags and the associated ULs are listed in the SMPTE ST 2109 Administrative Register at <https://smpte-ra.org/smp-te-st-2109-ar>

NOTE 2 More than one Audio Metadata section, including more than one section with the same Identifier, can exist.

NOTE 3 This standard does not define requirements on the presence of individual Audio Metadata payloads for each Edit Unit or the presence of random-access points, as defined in SMPTE ST 377-1.

### 4.3.4 Fill Data

The Fill Data may be used to pad each MGA Frame to a constant length if the length of Audio Essence and Audio Metadata sections is not constant for each MGA Frame of an essence container.

## 4.4 MGA Signal

An MGA Signal shall comprise of a sequence of MGA Frames.

The number of Audio Metadata sections shall be identical for all MGA Frames of an MGA Signal and the Index of each Audio Metadata section shall be constant.

An empty Audio Metadata payload in an Audio Metadata section of an MGA Frame shall be indicated by encoding the Length of the respective Audio Metadata section as zero.

## 5 Key-length-value coding

### 5.1 MGA Sound Element Key

The values of the first 12 bytes of the essence element key are defined in SMPTE ST 379-2. The values of the last four bytes of the MGA Sound Element key shall be as specified in Table 3. Byte 15 indicates a Frame-wrapped or Clip-wrapped MGA Sound Element.

**Table 3 — Key value for the MGA Sound Element**

Byte No.	Description	Value (hex)	Meaning
1~12	Defined by Generic Container		See SMPTE ST 379-2
13	Item Type Identifier	0x16	GC Sound Item (as defined in SMPTE ST 379-2)
14	Essence Element Count	0xkk	Count of Sound Elements in the Sound item (as defined in SMPTE ST 379-2)
15	Essence Element Type	0x0e 0x0f	Frame-wrapped MGA Sound Element Clip-wrapped MGA Sound Element
16	Essence Element Number	0xnn	The Number (used as an Index) of this Sound Element in the Sound Item (as defined in SMPTE ST 379-2)

### 5.2 MGA Sound Element Length

The length field shall comply with SMPTE ST 379-2.

### 5.3 MGA Sound Element Value

#### 5.3.1 Frame-wrapped

The value field shall comprise a single MGA Frame as defined in Section 4.3.

#### 5.3.2 Clip-wrapped

The value field shall comprise a sequence of one or more concatenated MGA Frames, where each MGA Frame is as defined in Section 4.3.

## 6 SMPTE Label Values

### 6.1 Essence Container Label

This Essence Container Label is the UL value carried in the Essence Containers Properties of the Partition Packs, Preface Set and File Descriptor. Partition Packs, Preface Set and File Descriptor are as defined in SMPTE ST 377-1.

The values for the essence container UL, as specified in SMPTE ST 379-2, shall be as given in Table 4.

**Table 4 — Specification of the Essence Container Label**

Item Name	Symbol	Kind	Item UL
MXF-GC MGA Audio Mappings	MXFGCMGAAudioMappings	NODE	urn:smpte:ul:060e2b34.0401010d.0d010301.02250000
MXF-GC Frame-wrapped MGA	MXFGCFFrameWrappedMGA	LEAF	urn:smpte:ul:060e2b34.0401010d.0d010301.02250100
MXF-GC Clip-wrapped MGA	MXFGCClipWrappedMGA	LEAF	urn:smpte:ul:060e2b34.0401010d.0d010301.02250200

### 6.2 Sound Essence Coding Label

The Label intended for use as value for the Sound Essence Coding item of the Generic Sound Essence Descriptor, specified in SMPTE ST 377-1, shall be as given in Table 5.

**Table 5 — Specification of the Sound Essence Coding Label**

Item Name	Symbol	Kind	Item UL
MGA Audio Essence Sound Coding Schemes	MGAAudioEssenceSoundCodingSchemes	NODE	urn:smpte:ul:060e2b34.0401010d.04020201.02000000
MGA Audio Essence Uncompressed Sound Coding	MGAAudioEssenceUncompressedSoundCoding	LEAF	urn:smpte:ul:060e2b34.0401010d.04020201.02010000

## 7 Application Issues

### 7.1 Index Table Usage

An Index Table should be present for both frame-wrapping and clip-wrapping.

The Random Access flag bit of the Index Entry Array structure, as defined in ST 377-1, shall be set to 0 if the corresponding Edit Unit and its associated Audio Metadata sections cannot be used to commence decoding an MGA Frame.

NOTE 1 Two options are available for achieving a constant edit unit size: (i) The fill section of an MGA Frame, or (ii) The KLV fill item in case of frame-wrapped MGA Sound Elements.

## SMPTE ST 2127-1:2022

SMPTE EG 377-3 illustrates the use of index tables for both mono and multi-essence mappings and for both constant and variable length edit unit sizes.

NOTE 2 As defined in SMPTE ST 377-1, the Index Edit Rate is equal to the Edit Rate of the MXF Essence Track.

# 8 Essence Descriptors

## 8.1 General

Top-level file packages whose associated Essence Containers contain one or more MGA Sound Elements according to this standard shall contain exactly one Strong Reference (direct or indirect via a Multiple Descriptor) to an MGA Sound Essence Descriptor for each corresponding Essence Track. The MGA Sound Essence Descriptor, as specified in Section 8.2, is a subclass of the Generic Sound Essence Descriptor, as defined in SMPTE ST 377-1.

The MGA Sound Essence Descriptor shall contain exactly one Strong Reference to an MGA Audio Metadata SubDescriptor for each present Audio Metadata section (see Section 4.3), as specified in Section 8.3.

The object model for the essence descriptors defined in this document is illustrated in Annex A.

## 8.2 MGA Sound Essence Descriptor

The MGA Sound Essence Descriptor shall consist of the properties as shown in Table 6 and Table 7.

The Essence Container Label item of the MGA Sound Essence Descriptor, as inherited from the File Descriptor, shall be as specified in Section 6.1.

The Sound Essence Coding Label item of the MGA Sound Essence Descriptor, as inherited from the Generic Sound Essence Descriptor, shall be as specified in Section 6.2.

The Sample Rate item of the MGA Sound Essence Descriptor, as inherited from the Generic Sound Essence Descriptor, shall be equal to the Edit Rate of the timeline track.

The Audio Sample Rate item of the MGA Sound Essence Descriptor, as inherited from the Generic Sound Essence Descriptor, shall be equal to the sampling rate of the MGA Audio Essence.

**Table 6 — Elements of the MGA Sound Essence Descriptor Set**

Symbol	Type	Len	Req ?	Meaning	Default
MGASoundEssenceDescriptor	Set UL	16	Req	MGA Sound Essence Descriptor	
<i>Length</i>	BER Length	Var	Req	Set length	
<i>All items from the Generic Sound Essence Descriptor as specified in SMPTE ST 377-1:2019 Section F.5</i>					
MGASoundEssenceBlockAlign	UInt16	2	Req	Specifies the block alignment of the data in bytes, as defined in SMPTE ST 382.	
MGASoundEssenceAverageBytesPerSecond	UInt32	4	Req	Specifies the average data rate in bytes per second, as defined in SMPTE ST 382.	

Symbol	Type	Len	Req ?	Meaning	Default
MGASoundEssenceSequenceOffset	UInt8	1	Opt	Zero-based ordinal frame number of first essence data within five-frame sequence (as defined in Section 6.2 of SMPTE ST 382:2007)	

**Table 7 — MGA Sound Essence Descriptor ULs**

Item Name	Symbol	Kind	Item UL
MGA Sound Essence Descriptor	MGASoundEssenceDescriptor	LEAF	urn:smpte:ul:060e2b34.027f0101.0d010101.01018106
MGA Sound Essence Coding Parameters	MGASoundEssenceCodingParameters	NODE	urn:smpte:ul:060e2b34.0101010e.04020304.00000000
MGA Sound Essence Block Align	MGASoundEssenceBlockAlign	LEAF	urn:smpte:ul:060e2b34.0101010e.04020304.01000000
MGA Sound Essence Average Bytes Per Second	MGASoundEssenceAverageBytesPerSecond	LEAF	urn:smpte:ul:060e2b34.0101010e.04020304.02000000
MGA Sound Essence Sequence Offset	MGASoundEssenceSequenceOffset	LEAF	urn:smpte:ul:060e2b34.0101010e.04020304.03000000

### 8.3 MGA Audio Metadata SubDescriptor

The MGA Audio Metadata SubDescriptor, which shall be a concrete subclass of the abstract SubDescriptor as defined in SMPTE ST 377-1, shall consist of the properties as shown in Table 8 and Table 9.

**Table 8 — Specification of the values of the MGA Audio Metadata SubDescriptor**

Symbol	Type	Len	Req ?	Meaning	Default
MGAAudioMetadataSubDescriptor	Set UL	16	Req	MGA Audio Metadata SubDescriptor	
<i>Length</i>	BER Length	Var	Req	Set length	
<i>All items from the abstract SubDescriptor as specified in SMPTE ST 377-1:2019 Annex B.3</i>					
MGALinkID	UUID	16	Req	Uniquely identifies the Audio Metadata section, and is used to link associated instances of SubDescriptors	
MGAAudioMetadataIndex	UInt8	1	Req	Index of the Audio Metadata section, as specified in Table 1, associated with this instance of the MGA Audio Metadata SubDescriptor	
MGAAudioMetadataIdentifier	UInt8	1	Req	Identifier of the Audio Metadata section, as specified in Table 2, associated with this instance of the MGA Audio Metadata SubDescriptor	

Symbol	Type	Len	Req ?	Meaning	Default
MGAAudioMetadataPayloadULArray	Array of UL	8+16n	Req	<i>If Identifier equals 0x01: All n ST 2109 Payload ULs present in the ST 2109 Audio Metadata Pack If Identifier equals 0x02: ST2109 Payload UL of the ST 2109 Payload (exactly one UL, n=1) If Identifier equals 0x03: Single Payload UL (exactly one UL, n=1)</i>	

**Table 9 — MGA Audio Metadata SubDescriptor ULs**

Item Name	Symbol	Kind	Item UL
MGA Audio Metadata SubDescriptor	MGAAudioMetadataSubDescriptor	LEAF	urn:smppte:u1:060e2b34.027f0101.0d010101.01018107
MGA Audio Metadata Coding Parameters	MGAAudioMetadataCodingParameters	NODE	urn:smppte:u1:060e2b34.0101010e.04020305.00000000
MGA Link ID	MGALinkID	LEAF	urn:smppte:u1:060e2b34.0101010e.04020305.01000000
MGA Audio Metadata Index	MGAAudioMetadataIndex	LEAF	urn:smppte:u1:060e2b34.0101010e.04020305.02000000
MGA Audio Metadata Identifier	MGAAudioMetadataIdentifier	LEAF	urn:smppte:u1:060e2b34.0101010e.04020305.03000000
MGA Audio Metadata Payload UL Array	MGAAudioMetadataPayloadULArray	LEAF	urn:smppte:u1:060e2b34.0101010e.04020305.04000000

## 9 Audio Labeling

### 9.1 General

Top-level file packages whose associated Essence Containers contain one or more MGA Sound Elements shall utilize the MCA Label framework as defined in SMPTE ST 377-4 and further extended in this section.

The MGA Sound Essence Descriptor may contain one or more Strong References to an MGA Soundfield Group Label SubDescriptor for each present Audio Metadata section (see Section 4.3), as specified in Section 9.2.

The SoundfieldGroupLabelSubDescriptor, as defined in SMPTE ST 377-4, shall not be present.

NOTE The MGA Soundfield Group Label SubDescriptor replaces the SoundfieldGroupLabelSubDescriptor as defined in SMPTE ST 377-4.

If the AudioChannelLabelSubDescriptor, as defined in SMPTE ST 377-4, is required for an MGA application, its usage should be defined in the related application standard.

Application standards should adopt the MCA Controlled Vocabulary as defined in SMPTE ST 377-41.

### 9.2 MGA Soundfield Group Label SubDescriptor

The MGA Soundfield Group Label SubDescriptor, which shall be a subclass of the SoundfieldGroupLabelSubDescriptor as defined in SMPTE ST 377-4:2021, shall consist of the properties as shown in Table 10 and Table 11.

All provisions defined in SMPTE ST 377-4 for the SoundfieldGroupLabelSubDescriptor shall apply to the MGA Soundfield Group Label SubDescriptor, with this exception: An MGA Soundfield Group Label SubDescriptor shall be referenced by zero or more AudioChannelLabelSubDescriptors.

**Table 10 — Specification of the values of the MGA Soundfield Group Label SubDescriptor**

Symbol	Type	Len	Req ?	Meaning	Default
MGASoundfieldGroupLabelSubDescriptor	Set UL	16	Req	MGA Soundfield Group Label SubDescriptor	
<i>Length</i>	BER Length	Var	Req	Set length	
<i>All items from the SoundfieldGroupLabelSubDescriptor as specified in SMPTE ST 377-4:2021 Section 6.5</i>					
MGAMetadataSectionLinkID	UUID	16	Req	MGA Link ID of the metadata section to which this SubDescriptor belongs, as defined in Table 8	

**Table 11 — MGA Soundfield Group Label SubDescriptor ULs**

Item Name	Symbol	Kind	Item UL
MGA Soundfield Group Label SubDescriptor	MGASoundfieldGroupLabelSubDescriptor	LEAF	urn:smpte:ul:060e2b34.027f0101.0d010101.01018108
MGA Soundfield Group Label Coding Parameters	MGASoundfieldGroupLabelCodingParameters	NODE	urn:smpte:ul:060e2b34.0101010e.04020306.00000000
MGA Metadata Section Link ID	MGAMetadataSectionLinkID	LEAF	urn:smpte:ul:060e2b34.0101010e.04020306.01000000

The MCA Label Dictionary ID, MCA Tag Symbol and MCA Tag Name items should take the values as defined in SMPTE ST 377-42 for Soundfield Groups. In addition, the combination of values defined in Table 12 may be used.

Application standards may constrain or extend the permitted values for MCA Label Dictionary ID, MCA Tag Symbol and MCA Tag Name as appropriate.

**Table 12 — MGA Soundfield Group Label SubDescriptor values**

Item	Value
MCA Label Dictionary ID	UL for an MGA Soundfield as defined in Table 13
MCA Tag Symbol	'MGASf'
MCA Tag Name	'MGA Soundfield'

**Table 13 — MGA Soundfield Label**

Item Name	Symbol	Kind	Item UL
MGA Soundfield	MGASoundfield	LEAF	urn:smpte:ul:060e2b34.0401010d.03020222.00000000

### 9.3 Usage of the GroupOfSoundfieldGroupsLabelSubDescriptor

An MGA Soundfield Group Label SubDescriptor may refer to a GroupOfSoundfieldGroupsLabelSubDescriptor as defined in SMPTE ST 377-4.

If an MGA Soundfield is part of a Group of Soundfield Groups, the GroupOfSoundfieldGroupsLinkID item of the MGA Soundfield Group Label SubDescriptor shall carry the MCA Link ID of the corresponding GroupOfSoundfieldGroupsLabelSubDescriptor.

The MCA Label Dictionary ID, MCA Tag Symbol and MCA Tag Name items may take any values defined in SMPTE ST 377-42 for Groups of Soundfield Groups.

Application standards may constrain or extend the permitted values for MCA Label Dictionary ID, MCA Tag Symbol and MCA Tag Name as appropriate.

## Annex A (Informative) Descriptor Object Model

The object model for the MGA Sound Essence Descriptor and the Audio Labeling Descriptors is shown in Figure A.1.

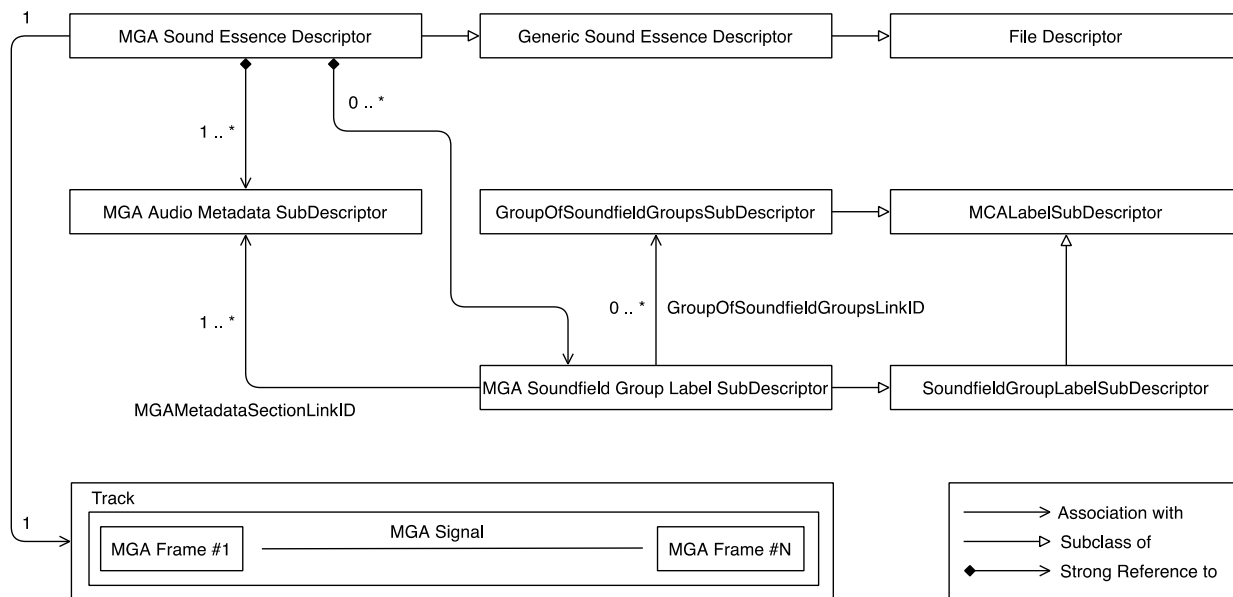

Figure A.1 — MGA Sound Essence Descriptor Object Model

## **Bibliography (Informative)**

SMPTE EG 377-3:2013 - Material Exchange Format (MXF) — Engineering Guideline (Informative)