

## 1.5 Gb/s Signal/Data Serial Interface



Table of Contents	Page
Foreword .....	2
Intellectual Property .....	2
Introduction.....	2
1 Scope .....	3
2 Conformance Notation .....	3
3 Normative References .....	3
4 Source Format Data.....	4
5 Interface Data Format .....	5
6 Serial Data Format.....	6
7 Channel Coding .....	7
8 Coaxial Cable Interface.....	7
9 Payload Identifier .....	9
Annex A Channel Code (Informative) .....	13
Annex B Bibliography (Informative) .....	14
Annex C Document Road Map (Informative).....	15
Annex D Timing Reference Codes (Informative).....	16
Annex E Source Signal Formats (Informative).....	17
Annex F Audio Data Mapping (Informative).....	19

## Foreword

SMPTE (the Society of Motion Picture and Television Engineers) is an internationally-recognized standards developing organization. Headquartered and incorporated in the United States of America, SMPTE has members in over 80 countries on six continents. SMPTE's Engineering Documents, including Standards, Recommended Practices and Engineering Guidelines, are prepared by SMPTE's Technology Committees. Participation in these Committees is open to all with a bona fide interest in their work. SMPTE cooperates closely with other standards-developing organizations, including ISO, IEC and ITU.

SMPTE Engineering Documents are drafted in accordance with the rules given in Part XIII of its Administrative practices.

SMPTE ST 292-1 was prepared by Technology Committee 32NF.

## Intellectual Property

At the time of publication no notice had been received by SMPTE claiming patent rights essential to the implementation of this Standard. However, attention is drawn to the possibility that some of the elements of this document may be the subject of patent rights. SMPTE shall not be held responsible for identifying any or all such patent rights.

## Introduction

This section is entirely informative and does not form an integral part of this Engineering Document.

This standard has been developed to carry HDTV digital video signals and formatted data within the defined payload areas including ancillary data. The standard can carry 1280x720, 1920x1080 or 2048x1080 active pixel formats through the 1.5 Gb/s Serial Digital Interface and enables the carriage of any ancillary data conforming to SMPTE ST 291.

## 1 Scope

This standard defines a bit-serial data structure and the coaxial cable interface specifications for 1.5 Gb/s [nominal] Signal/Data Serial Interface to carry either 1280×720, 1920×1080 or 2048×1080 active pixel formats mapped into the 1.5 Gb/s payload. This standard defines the method of serializing the parallel source format data to a serial bit stream. This interface may also carry packetized data mapped into the 1.5 Gb/s transport payload providing the constraints imposed by the reference source image formats are observed.

This standard specifies a coaxial cable interface suitable for application where the signal loss does not exceed an amount specified by the receiver manufacturer, typical loss amounts would be in the range of up to 20 dB at one-half the clock frequency.

## 2 Conformance Notation

Normative text is text that describes elements of the design that are indispensable or contains the conformance language keywords: "shall", "should", or "may". Informative text is text that is potentially helpful to the user, but not indispensable, and can be removed, changed, or added editorially without affecting interoperability. Informative text does not contain any conformance keywords.

All text in this document is, by default, normative, except: the Introduction, any section explicitly labeled as "Informative" or individual paragraphs that start with "Note:"

The keywords "shall" and "shall not" indicate requirements strictly to be followed in order to conform to the document and from which no deviation is permitted.

The keywords, "should" and "should not" indicate that, among several possibilities, one is recommended as particularly suitable, without mentioning or excluding others; or that a certain course of action is preferred but not necessarily required; or that (in the negative form) a certain possibility or course of action is deprecated but not prohibited.

The keywords "may" and "need not" indicate courses of action permissible within the limits of the document.

The keyword "reserved" indicates a provision that is not defined at this time, shall not be used, and may be defined in the future. The keyword "forbidden" indicates "reserved" and in addition indicates that the provision will never be defined in the future.

## 3 Normative References

Note: All references in this document to other SMPTE documents use the current numbering style (e.g. SMPTE ST 274:2008) although, during a transitional phase, the document as published (printed or PDF) may bear an older designation (such as SMPTE 274M-2008). Documents with the same root number (e.g. 274) and publication year (e.g. 2008) are functionally identical.

The following standards contain provisions which, through reference in this text, constitute provisions of this standard. At the time of publication, the editions indicated were valid. All standards are subject to revision, and parties to agreements based on this standard are encouraged to investigate the possibility of applying the most recent edition of the standards indicated below.

SMPTE ST 274:2008, Television — 1920 x 1080 Image Sample Structure, Digital Representation and Digital Timing Reference Sequences for Multiple Picture Rates

SMPTE ST 296:2001, Television — 1280 x 720 Progressive Image Sample Structure — Analog and Digital Representation and Analog Interface (R2006)

SMPTE ST 352:2011, Payload Identification Codes for Serial Digital Interfaces

SMPTE ST 2048-2:2011, 2048 x 1080 Digital Cinematography Production Image FS/709 Formatting for Serial Digital Interface

SMPTE RP 184:2004, Specification of Jitter in Bit-Serial Digital Systems

IEC 61169-8 (2007-2), Part 8: Sectional Specification — R.F. Coaxial Connectors with Inner Diameter of Outer Conductor 6,5 mm (0,256 in) with Bayonet Lock — Characteristic Impedance 50Ω (Type BNC), Annex A (Normative) Information for Interface Dimensions of 75Ω Characteristic Impedance Connector with Unspecified Reflection Factor<sup>1</sup>

## 4 Source Format Data

**4.1** For this interface, the source data shall be 10-bit words. The source data may be an uncompressed video source or packetized data constrained by the pixel array of the referenced source image formats.

**4.2** For uncompressed 4:2:2 HDTV or 2048x1080 pixel signals, the interface shall be two parallel bit streams. One stream shall be defined as the Luma (Y') data channel, and the second stream shall be the Color-Difference (C<sub>B</sub>, C<sub>R</sub>) data channel. These data channels shall be multiplexed to form the serial data stream. The multiplexing shall be as defined in Figure 3. Other mappings shall be defined by application documents.

**4.3** Data for each line of the interface shall be divided into four areas: SAV (start of active video) timing reference, digital active line, EAV (end of active video) timing reference, LN (Line number), CRC (Cyclic Redundancy Check Code), and digital line blanking as shown in Figure 1. The number of words and defined data in each area shall be specified by the source format or mapping documents.

**4.4** Parameters for uncompressed HDTV and 2048x1080 pixel sources and associated ancillary space shall be defined by:

SMPTE ST 274  
 SMPTE ST 296  
 SMPTE ST 2048-2  
 (See informative Annex E.)

The total data rate shall be either 1.485 Gb/s or 1.485/1.001 Gb/s. The source format or mapping documents determine the precise interface clock frequency<sup>2</sup>.

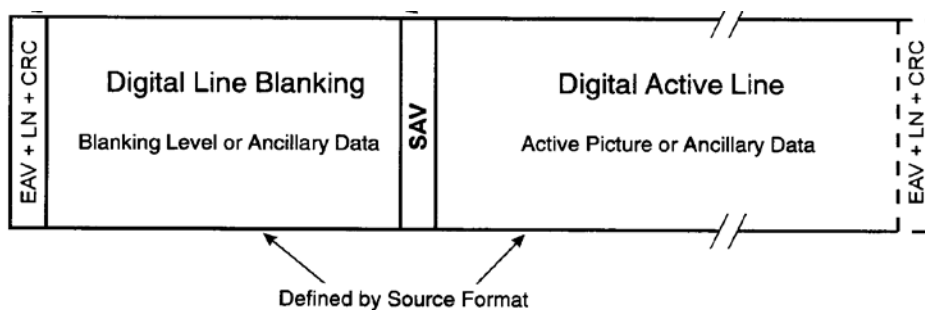

**Figure 1 – Interface horizontal line data**

<sup>1</sup> Please note that the title of this normative reference could be misleading. This standard requires the use of the 75-ohm connector defined in this reference.

<sup>2</sup> Designers are encouraged to refer to multi-link 1.5 Gb/s-SDI or higher data rate SDI documents for the image formats which require higher than 1.485 Gb/s or 1.485/1.001 Gb/s.

## 5 Interface Data Format

5.1 Digital active line and digital line blanking shall consist of 10-bit words as defined by the source format document. Data values 000h to 003h and 3FCh to 3FFh shall be used exclusively for synchronization purposes.<sup>3</sup>

5.2 Timing references SAV, EAV, line number, and CRCs for each of the two parallel data streams shall be formatted as shown in Figure 2.

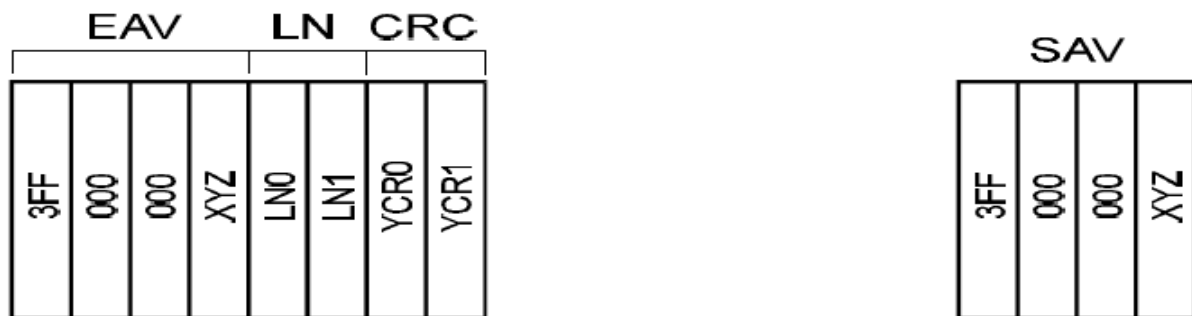

Figure 2 – Timing reference format (Luma channel shown)

5.3 Interface line number data shall be composed of two words and shall be as shown in Table 1.

5.4 CRC (cyclic redundancy check codes) shall be used to detect errors in the active digital line, including EAV and LN. The error detection code shall consist of two words determined by the polynomial generator equation:

$$\text{CRC}(X) = X^{18} + X^5 + X^4 + 1$$

The initial value of the CRC shall be set to zero. The calculation shall start at the first active line word and shall end at the final word of the line number data, LN1. Two CRCs shall be calculated, one for the luma data channel and one for the color-difference data channel of the interface, as shown in Table 2.

Luma channel and color-difference channel of the interface may carry packetized data as defined by other application documents providing the constraints defined in this standard and that of the source image formats are observed.

5.5 Available ancillary data space shall be defined by the source format. Attention is drawn to the reduced sample number of H-Blank by  $2048 - 1920 = 128$  when transporting  $2048 \times 1080$  active image formats. (See informative Annex F.)

<sup>3</sup> SMPTE ST 291 Ancillary data packets use these values for identification.

**Table 1 – Line number data**

Word	9 (MSB)	8	7	6	5	4	3	2	1	0 (LSB)
LN0	$\overline{B8}$	L6	L5	L4	L3	L2	L1	L0	R	R
LN1	$\overline{B8}$	R	R	R	L10	L9	L8	L7	R	R
NOTES 1 L0 – L10 = line number in binary code. 2 R = reserved, set to "0".										

**Table 2 – CRC data**

Word	9 (MSB)	8	7	6	5	4	3	2	1	0 (LSB)
YCR0	$\overline{B8}$	CRC8	CRC7	CRC6	CRC5	CRC4	CRC3	CRC2	CRC1	CRC0
YCR1	$\overline{B8}$	CRC17	CRC16	CRC15	CRC14	CRC13	CRC12	CRC11	CRC10	CRC9
CCR0	$\overline{B8}$	CRC8	CRC7	CRC6	CRC5	CRC4	CRC3	CRC2	CRC1	CRC0
CCR1	$\overline{B8}$	CRC17	CRC16	CRC15	CRC14	CRC13	CRC12	CRC11	CRC10	CRC9

## 6 Serial Data Format

6.1 The two source format parallel data streams with EAV and SAV shall be as shown in Figure 2 and shall be interleaved as shown in Figure 3.

6.2 Interleaved data shall be serialized with the LSB (least significant bit) of each data word transmitted first.

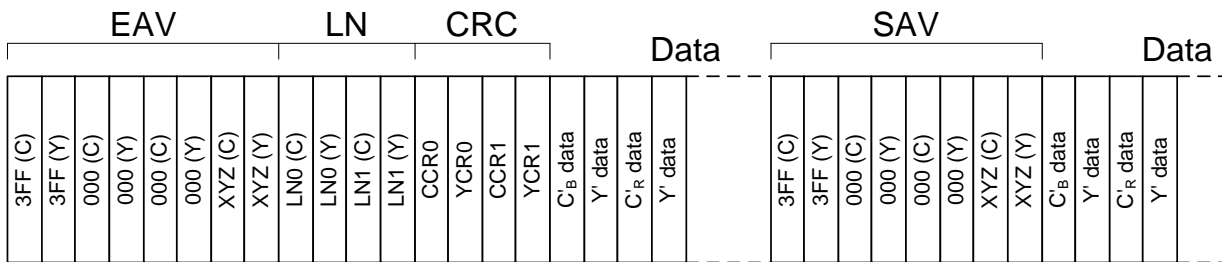

**Figure 3 – Interleaved data stream**

## 7 Channel Coding

7.1 The channel coding scheme shall be scrambled NRZI (non-return to zero inverted). (See Annex A.)

7.2 The generator polynomial for the scrambled NRZ shall be  $G_1(X) = X^9 + X^4 + 1$ . Polarity-free scrambled NRZI sequence data shall be produced by the generator polynomial  $G_2(X) = X + 1$ . The input signal to the scrambler shall be positive logic. (The highest voltage represents data 1 and the lowest voltage represents data 0.)

7.3 The serial interface data word length shall be 10 bits.

## 8 Coaxial Cable Interface

### 8.1 Signal Levels and Specifications

These specifications shall be defined for measurement of the serial output of a source derived from a parallel domain signal.

8.1.1 The output of the generator shall be measured across a 75-ohm resistive load connected through a 1-m coaxial cable. Figure 4 defines the measurement dimensions for amplitude, rise-time and overshoot.

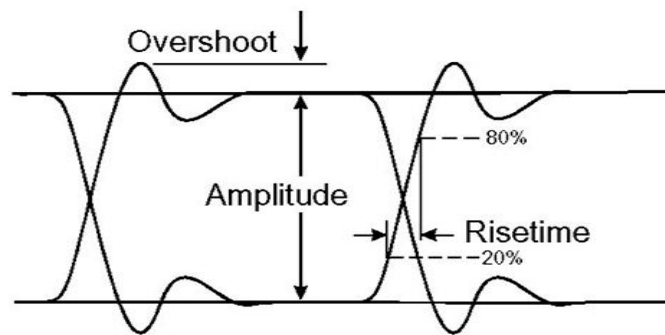

Figure 4 – Waveform measurement dimensions

8.1.2 The generator shall have an unbalanced output circuit with a source impedance of 75 ohms and a return loss of at least 15 dB over a frequency range of 5 MHz to the clock frequency of the signal being transmitted.

8.1.3 The peak-to-peak signal amplitude shall be  $800 \text{ mV} \pm 10\%$  measured as specified in § 8.1.1.

8.1.4 The dc offset, as defined by the mid-amplitude point of the signal, shall be nominally  $0.0 \text{ V} \pm 0.5 \text{ V}$ .

8.1.5 The rise and fall times, determined between the 20% and 80% amplitude points shall be no greater than 270 ps and shall not differ by more than 100 ps.

8.1.6 Overshoot of the rising and falling edges of the waveform shall not exceed 10% of the amplitude.

**8.1.7** Output amplitude excursions due to signals with a significant dc component occurring for a horizontal line (pathological signals) shall not exceed 50 mV above or below the average peak-to-peak signal envelope.

Note: This specification defines a minimum output coupling time constant.

**8.1.8** The jitter in the timing of the transitions of the data signal shall be measured in accordance with SMPTE RP 184. Measurement parameters shall be as defined in SMPTE RP 184 and shall have the values shown in Table 3 for compliance with this standard.

**8.1.9** The receiver of the serial interface signal shall present an impedance of 75 ohms with a return loss of at least 15 dB over a frequency range of 5 MHz to the clock frequency of the signal being transmitted.

**8.1.10** Receivers operating with input cable losses in the range of up to 20 dB at one-half the clock frequency are nominal; however, receivers designed to work with greater or lesser signal attenuation are acceptable.

**8.1.11** When connected to a line driver operating at the lower limit of voltage permitted by § 8.1.3, the receiver should sense correctly the binary data in the presence of the superimposed interfering signal at the following levels:

dc	± 2.5V
Below 5 kHz	<2.5V p-p
5 kHz to 27 MHz	<100 mV p-p
Above 27 MHz	<40 mV p-p

**Table 3 – Jitter specifications**

B1	10 Hz	Timing jitter lower band edge
B2	100 kHz	Alignment jitter lower band edge
B3	> 1/10 the clock rate	Upper band edge
A1	1 UI	Timing jitter (Note 1)
A2	0.2 UI	Alignment jitter (UI = unit interval)
Test signal	Color bar test signal	(Note 2)
n	≠10 (preferred)	Serial clock divided (Note 3)

Notes:

- 1 Designers are cautioned that parallel signals could contain jitter up to 2 ns p-p. Direct conversion of such signals from parallel to serial could result in excessive serial signal jitter.
- 2 Color bars are chosen as a nonstressing test signal for jitter measurements. Use of a stressing signal with long runs of zeros could give misleading results.
- 3 Use of a serial clock divider value of 10 could mask word correlated jitter components.
- 4 See SMPTE RP 184 for definition of terms.

**8.2 Connector and Cable Types**

**8.2.1** The male and female connectors shall be 75-ohm BNC as defined in IEC 61169-8, Part 8, Annex A.

**8.2.2** Application of this standard does not require a particular type of coaxial cable. It is necessary for the frequency response of the coaxial cable loss, in decibels, to be approximately proportional to  $1/\sqrt{f}$  from 1 MHz to the clock frequency of the signal being transmitted to ensure correct operation of automatic cable equalizers over moderate to maximum lengths.

**8.2.3** Return loss of the correctly terminated transmission line shall be greater than 15 dB over a frequency range of 5 MHz to the clock frequency of the signal being transmitted.

## **9 Payload Identifier**

**9.1** A payload identifier is optional, and when present should be inserted into the horizontal ancillary data space of the Luma (Y') data channel.

The format of the payload identifier shall be in accordance with SMPTE ST 352.

### **9.2 Placement of the Ancillary Data Packet**

As this packet defines a basic payload type, the preferred horizontal placement of the ancillary data packet is immediately following the word YCR1, shown in Figure 2.

Implementers should be aware that the preferred horizontal and vertical locations for the Payload Identification Code packets are recommendations only. The actual packet location may vary on a case by case basis. Decoder manufacturers shall not depend on the recommended location for the detection and extraction of the payload packet.

Note: The line numbers given in the remainder of this section are interface line numbers which may differ from the picture source line numbers. These line number differences occur when using special raster mappings such as PsF, multi-link and multi-channel.

#### **9.2.1 750-line digital interfaces, progressive**

For digital interfaces having 750 lines with a progressive (P) scanning structure, the ancillary data packet shall be added once per frame on the Y-channel. The recommended location of the ancillary packet, if ancillary space is available, shall be on the following line:

750P: Line 10

#### **9.2.2 1125-line digital interfaces, interlace and segmented-frame**

For digital interfaces having 1125 lines with interlaced (I) and progressive segmented-frame (PsF) scanning structures, the ancillary data packet shall be added once per field on the Y-channel. The recommended location of the ancillary packet, if ancillary space is available, shall be on the following lines:

1125I (field 1): Line 10  
1125I (field 2): Line 572

Note: These line numbers also apply to dual-link HD-SDI when using interlaced and progressive segmented-frame scanning.

#### **9.2.3 1125-line digital interfaces, progressive**

For digital interfaces having 1125 lines with a progressive (P) scanning structure, the ancillary data packet shall be added once per frame on the Y-channel. The recommended location of the ancillary packet, if ancillary space is available, shall be on the following line:

1125P: Line 10

9.3 The payload identifier shall be 4 bytes long where each byte has a separate significance. The first byte of the payload identifier shall have the highest significance and subsequent bytes shall be used to define lower order payload information as defined in SMPTE ST 352.

The precise definition of the 4 byte payload identifier packet for 720-line and 1080-line payloads shall be as defined below and these definitions shall supersede the definitions contained in Annex B of SMPTE ST 352.

The values for byte 1 are contained in a register published on line at SMPTE RA < www.smp-te-ra.org>. Readers are encouraged to check the online site for the current registered values for each payload format and interface combination.

9.4 720-line Payloads on a 1.485 Gb/s (Nominal) Serial Digital Interface

Table 4 – Payload identifier definitions for 720-line progressive payloads on a 1.485 Gb/s (nominal) serial digital interface

Bits	Byte 1	Byte 2	Byte 3	Byte 4
Bit 7	1	Reserved	Reserved	Reserved
Bit 6	0	Progressive (1) picture	Reserved	Reserved
Bit 5	0	Reserved	Reserved	Reserved
Bit 4	0	Reserved	Reserved	Reserved
Bit 3	0	Picture rate (see SMPTE ST 352)	Sampling structure 4:2:2 (0h)	Reserved
Bit 2	1			Reserved
Bit 1	0			Reserved
Bit 0	0			Bit depth 8-bit (0) or 10-bit (1)

9.4.1 Byte 2

The second byte shall be used to identify the picture rate and the picture and transport scanning methods.

- The progressive picture flag bit b6 of Byte 2 shall be set to (1);
- The picture rate bits b3 to b0 of Byte 2 shall only use the values as defined in SMPTE ST 296 and shall be as defined in SMPTE ST 352;
- All other bits shall be Reserved and set to (0).

9.4.2 Byte 3

The third byte should be used to identify the sampling structure of the payload.

- The sampling structure bits b3 to b0 of Byte 3 shall be set to (0) 4:2:2;
- All other bits shall be Reserved and set to (0).

### 9.4.3 Byte 4

The fourth byte shall be used to identify extended aspects of the payload.

- Identification of the quantization value shall be specified in bit b0 of byte 4. The default value shall be (0) identifying a payload quantization resolution of 8 bits.
- All other bits shall be Reserved and set to (0).

## 9.5 1080-line Payloads on a 1.485 Gb/s (Nominal) Serial Digital Interface

**Table 5 – Payload identifier definitions for 1080-line interlaced and progressive payloads on a 1.485 Gb/s (nominal) serial digital interface**

Bits	Byte 1	Byte 2	Byte 3	Byte 4
Bit 7	1	Interlaced (0) or progressive (1) transport	Reserved	Reserved
Bit 6	0	Interlaced (0) or progressive (1) picture	Horizontal pixel count 1920 (0) or 2048 (1)	Reserved
Bit 5	0	Reserved	Aspect ratio 16:9 (1), unknown (0)	Reserved
Bit 4	0	Reserved	Reserved	Reserved
Bit 3	0	Picture rate (see SMPTE ST 352)	Sampling structure (see Table 6)	Reserved
Bit 2	1			Reserved
Bit 1	0			Reserved
Bit 0	1			Bit depth 8-bit (0) or 10-bit (1)

### 9.5.1 Byte 2

The second byte shall be used to identify the picture rate and the picture and transport scanning methods.

Bit b7 shall be used to identify whether the digital interface uses a progressive or interlaced transport structure such that:

b7 = (0) identifies an interlaced transport

b7 = (1) identifies a progressive transport

Bit b6 shall be used to identify whether the picture has a progressive or interlaced structure such that.

b6 = (0) identifies an interlaced structure

b6 = (1) identifies a progressive structure

Note: PsF payloads are identified by a progressive scanning of the payload transported over an interlaced digital interface transport carrying the progressive payload as a first and second picture segment within the transport frame duration. These first and second picture segments are indicated by the first and second field indicators in the digital interface transport.

Bits b5 to b4 shall be set to (0).

Bits b3 to b0 shall be used to identify the picture rate in Hz in accordance with Table 5 and shall be restricted to the frame rates defined in SMPTE ST 274 and SMPTE ST 2048-2.

**9.5.2 Byte 3**

The third byte shall be used to identify the aspect ratio and sampling structure of the payload as shown in Table 5.

Bit b6 shall be used to identify horizontal Pixel count

- (0) 1920 Pixels
- (1) 2048 Pixels

Bit b5 shall be used to identify the image aspect ratio

- (0) aspect ratio unknown
- (1) 16x9 image

- Bits b3 to b0 of byte 3 shall be used to identify the horizontal sampling structure in accordance with Table 6. This standard is constrained to values 0h and 3h.
- Bits b7 and b4 shall be Reserved and set to (0).

**Table 6 – Sampling Structure**

Value	Sampling	Value	Sampling	Value	Sampling	Value	Sampling
0h	4:2:2 (Y'/C' <sub>B</sub> /C' <sub>R</sub> )	1h	4:4:4 (Y'/C' <sub>B</sub> /C' <sub>R</sub> )	2h	4:4:4 (G'/B'/R')	3h	4:2:0
4h	4:2:2:4 (Y'/C' <sub>B</sub> /C' <sub>R</sub> /A)	5h	4:4:4:4 (Y'/C' <sub>B</sub> /C' <sub>R</sub> /A)	6h	4:4:4:4 (G'/B'/R'/A)	7h	SMPTE ST 2048-2 FS <sup>4</sup>
8h	4:2:2:4 (Y'/C' <sub>B</sub> /C' <sub>R</sub> /D)	9h	4:4:4:4 (Y'/C' <sub>B</sub> /C' <sub>R</sub> /D)	Ah	4:4:4:4 (G'/B'/R'/D)	Bh	Reserved
Ch	Reserved	Dh	Reserved	Eh	4:4:4 (X'Y'Z)	Fh	Reserved

**9.5.3 Byte 4**

The fourth byte shall be used to identify extended aspects of the payload.

Bits b7 to b1 are Reserved and set to (0).

Bit b0 shall be used to identify the bit depth of the sample quantization such that:

- (0) identifies quantization using 8 bits per sample;
- (1) identifies quantization using 10 bits per sample;

---

<sup>4</sup> SMPTE ST 2048-2 requires an addition of Color VANC packet in the vertical ancillary data space (VANC) to describe the FS characteristics – see SMPTE ST 2048-2.

### Annex A Channel Code (Informative)

When scrambled NRZI channel coding is applied to certain video signals (informally called pathological signals), repeated long strings of 19 or 20 zeros can occur during the period of one horizontal television line. A stressing test signal is defined in SMPTE RP 198 that will help in evaluating channel performance.

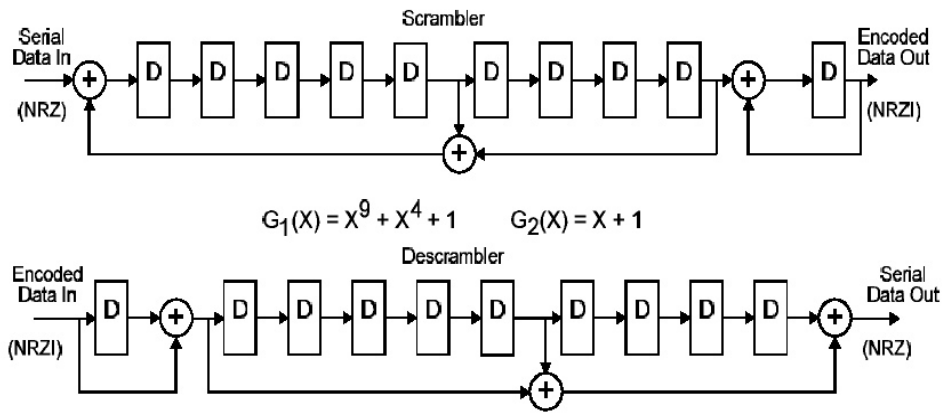

Figure A.1 – Example 1 of a possible implementation

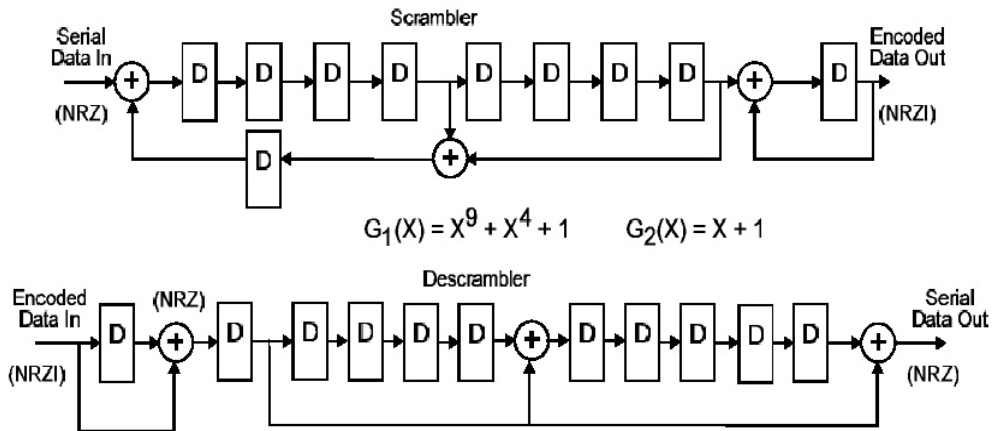

Figure A.2 – Example 2 of a possible implementation

## **Annex B Bibliography (Informative)**

Note: All references in this document to other SMPTE documents use the current numbering style (e.g. SMPTE ST 259:2008) although, during a transitional phase, the document as published (printed or PDF) may bear an older designation (such as SMPTE 259M-2008). Documents with the same root number (e.g. 259) and publication year (e.g. 2008) are functionally identical.

SMPTE ST 259:2008, Television — SDTV Digital Signal/Data — Serial Digital Interface

SMPTE ST 291:2010, Ancillary Data Packet and Space Formatting

SMPTE ST 2048-1:2011, 2048 x 1080 and 4096 x 2160 Digital Cinematography Production Image Formats FS/709

SMPTE RP 198:1998, Bit-Serial Digital Checkfield for Use in High-Definition Interfaces

Annex C Document Road Map (Informative)

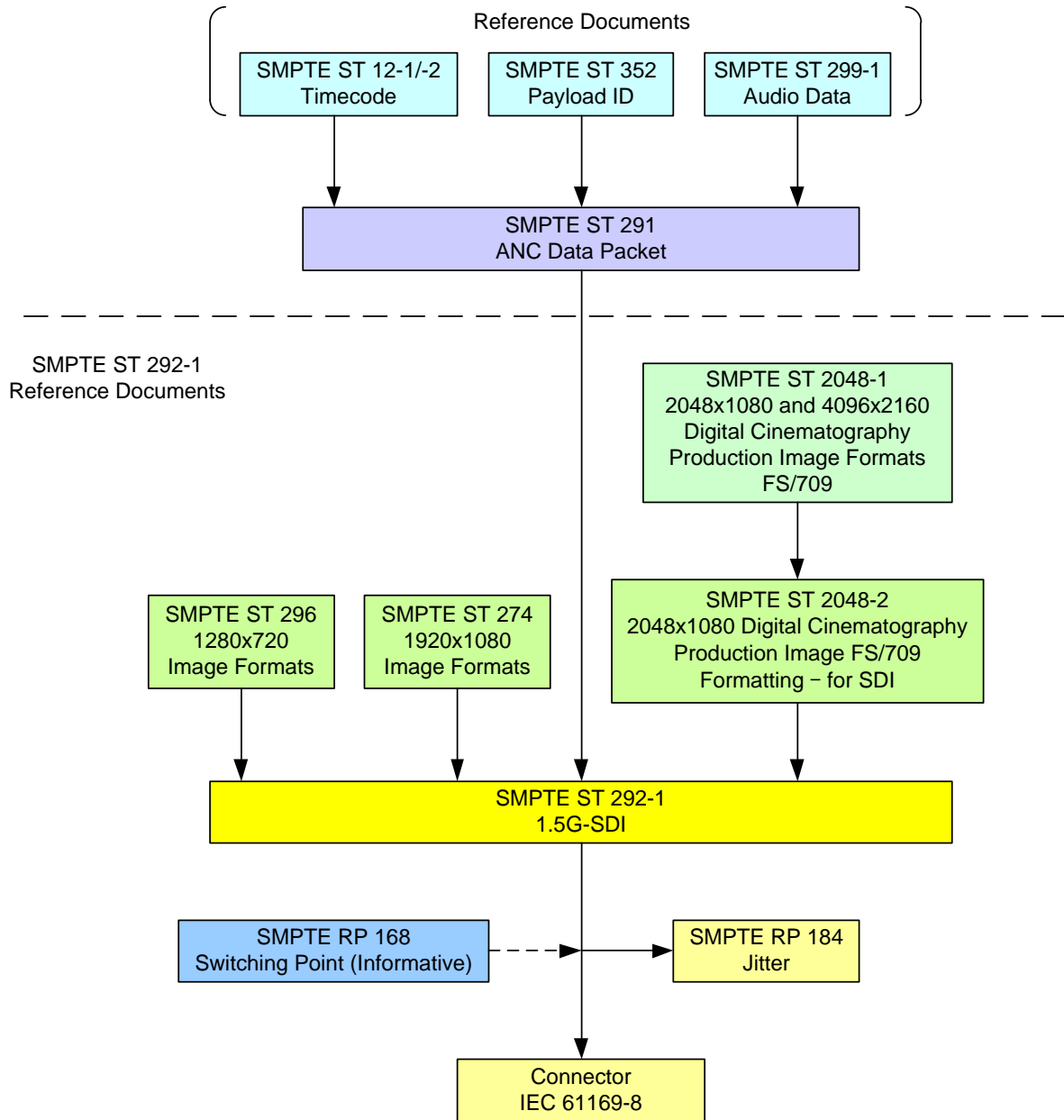

### Annex D Timing Reference Codes (Informative)

These codes, specified in the video source standards, are included as a convenience to designers.

Word	9 (MSB)	8	7	6	5	4	3	2	1	0 (LSB)
3FF	1	1	1	1	1	1	1	1	1	1
000	0	0	0	0	0	0	0	0	0	0
000	0	0	0	0	0	0	0	0	0	0
XYZ	1	F	V	H	P3	P2	P1	P0	0	0

Notes:

- 1 F = 0 during field 1; F = 1 during field 2.
- 2 V = 0 elsewhere; V = 1 during field blanking.
- 3 H = 0 in SAV; H = 1 in EAV.
- 4 MSB = most significant bit; LSB = least significant bit.
- 5 P0, P1, P2, P3 are protection bits defined below.

Bit	9 (MSB)	8	7	6	5	4	3	2	1	0 (LSB)
	1 Fixed	F	V	H	P3	P2	P1	P0	0 Fixed	0 Fixed
200h	1	0	0	0	0	0	0	0	0	0
274h	1	0	0	1	1	1	0	1	0	0
2ACh	1	0	1	0	1	0	1	1	0	0
2D8h	1	0	1	1	0	1	1	0	0	0
31Ch	1	1	0	0	0	1	1	1	0	0
368h	1	1	0	1	1	0	1	0	0	0
3B0h	1	1	1	0	1	1	0	0	0	0
3C4h	1	1	1	1	0	0	0	1	0	0

## Annex E Source Signal Formats (Informative)

### SMPTE ST 274 —

System No.	System nomenclature	Luma or R'G'B' samples per active line (S/AL)	Active lines per frame (AL/F)	Frame rate (Hz)	Interface sampling frequency fs (MHz)	Luma sample periods per total line (S/TL)	Total lines per frame
1	1920 × 1080/60/P	1920	1080	60	148.5	2200	1125
2	1920 × 1080/59.94/P	1920	1080	$\frac{60}{1.001}$	$\frac{148.5}{1.001}$	2200	1125
3	1920 × 1080/50/P	1920	1080	50	148.5	2640	1125
4	1920 × 1080/60/I	1920	1080	30	74.25	2200	1125
5	1920 × 1080/59.94/I	1920	1080	$\frac{30}{1.001}$	$\frac{74.25}{1.001}$	2200	1125
6	1920 × 1080/50/I	1920	1080	25	74.25	2640	1125
7	1920 × 1080/30/P	1920	1080	30	74.25	2200	1125
8	1920 × 1080/29.97/P	1920	1080	$\frac{30}{1.001}$	$\frac{74.25}{1.001}$	2200	1125
9	1920 × 1080/25/P	1920	1080	25	74.25	2640	1125
10	1920 × 1080/24/P	1920	1080	24	74.25	2750	1125
11	1920 × 1080/23.98/P	1920	1080	$\frac{24}{1.001}$	$\frac{74.25}{1.001}$	2750	1125

A single link 1.5 Gb/s-SDI can transport 1920×1080/4:2:2/23.98P-30P (or PsF) or 50I-60I/10-bit as defined by SMPTE ST 274. Refer to multi-link 1.5 Gb/s-SDI documents for higher data rate SDI transports.

### SMPTE ST 296 —

System No.	System nomenclature	Luma or R'G'B' samples per active line (S/AL)	Active lines per frame (AL/F)	Frame rate (Hz)	Luma or R'G'B' sampling frequency fs (MHz)	Luma sample periods per total line (S/TL)	Total lines per frame
1	1280 × 720/60	1280	720	60	74.25	1650	750
2	1280 × 720/59.94	1280	720	60/1.001	74.25/1.001	1650	750
3	1280 × 720/50	1280	720	50	74.25	1980	750
4	1280 × 720/30	1280	720	30	74.25	3300	750
5	1280 × 720/29.97	1280	720	30/1.001	74.25/1.001	3300	750
6	1280 × 720/25	1280	720	25	74.25	3960	750
7	1280 × 720/24	1280	720	24	74.25	4125	750
8	1280 × 720/23.98	1280	720	24/1.001	74.25/1.001	4125	750

A single link 1.5 Gb/s-SDI can transport 1280×720/4:2:2/23.98P-60P/10-bit as defined by SMPTE ST 296. Refer to multi-link 1.5 Gb/s-SDI documents for higher data rate SDI transports.

**SMPTE ST 2048-2 —**

System No.	System nomenclature	Luma or R'G'B' samples per active line (S/AL)	Active lines per frame (AL/F)	Frame rate (Hz)	Interface sampling frequency fs (MHz)	Luma sample periods per total line (S/TL)	Total lines per frame
1	2048 x 1080/60/P	2048	1080	60	148.5	2200	1125
2	2048 x 1080/59.94/P	2048	1080	$\frac{60}{1.001}$	$\frac{148.5}{1.001}$	2200	1125
3	2048 x 1080/50/P	2048	1080	50	148.5	2640	1125
4	2048 x 1080/48/P	2048	1080	48	148.5	2750	1125
5	2048 x 1080/47.95/P	2048	1080	$\frac{48}{1.001}$	$\frac{148.5}{1.001}$	2750	1125
6	2048 x 1080/30/P	2048	1080	30	74.25	2200	1125
7	2048 x 1080/29.97/P	2048	1080	$\frac{30}{1.001}$	$\frac{74.25}{1.001}$	2200	1125
8	2048 x 1080/25/P	2048	1080	25	74.25	2640	1125
9	2048 x 1080/24/P	2048	1080	24	74.25	2750	1125
10	2048 x 1080/23.98/P	2048	1080	$\frac{24}{1.001}$	$\frac{74.25}{1.001}$	2750	1125

A single link 1.5 Gb/s-SDI can transport 2048x1080/4:2:2/23.98P-30P or PsF/10-bit in SMPTE ST 2048-1. Refer to multi-link 1.5 Gb/s-SDI documents for higher data rate SDI transports.

## **Annex F Audio Data Mapping (Informative)**

When transporting the image formats corresponding to system numbers 1, 2, 6 and 7 defined in SMPTE ST 2048-2 through single-link or multiple-link SMPTE ST 292-1 (HD-SDI) interface, the maximum number of 32 kHz to 48 kHz sampling audio channels transported per single-link SMPTE ST 292-1 is reduced from 16 channels to 8 channels (4 channels in the case of 96 kHz sampling).