

SMPTE STANDARD

D-Cinema Packaging — DCP Operational Constraints — Amendment 1



Table of Contents

	Page
Foreword	2
1 Scope	3
2 Add the following Normative References	3
3 Remove the following Normative References	3
4 Replace the text of Section 8.3 ("Sound Essence Encoding") in its entirety by the following.	3
5 Replace the text of Annex A ("Audio Channel Assignment Label ") in its entirety by the following.	3
Annex A.1 Static Container Channel Configurations	3
A.1.1 Channel Label Set ULs	4
A.1.2 Channel Configuration Tables	5
Annex A.2 Configurations using MXF Multichannel Audio Framework	6
A.2.1 Configuration Channel Assignment Label	8
A.2.2 AudioChannelLabelSubDescriptor	8
A.2.2.1 Common D-Cinema Channels	9
A.2.2.2 Extension Channels	9
A.2.3 SoundfieldGroupLabelSubDescriptor	9
A.2.3.1 Common D-Cinema Soundfield Groups	9
A.2.3.2 Extension Soundfield Groups	10

Foreword

SMPTE (the Society of Motion Picture and Television Engineers) is an internationally-recognized standards developing organization. Headquartered and incorporated in the United States of America, SMPTE has members in over 80 countries on six continents. SMPTE's Engineering Documents, including Standards, Recommended Practices and Engineering Guidelines, are prepared by SMPTE's Technology Committees. Participation in these Committees is open to all with a bona fide interest in their work. SMPTE cooperates closely with other standards-developing organizations, including ISO, IEC and ITU.

SMPTE Engineering Documents are drafted in accordance with the rules given in Part XIII of its Operations Manual.

Amendment 1 to SMPTE ST 429-2 was prepared by Technology Committee 21DC.

1 Scope

This amendment applies the MXF Multichannel Audio Framework to the D-Cinema Package. It allows for the unambiguous labeling of audio channels and soundfield groups contained in D-Cinema Sound Track Files.

2 Add the following Normative References

[SMPTE ST 428-12] SMPTE ST 428-12:2013, D-Cinema Distribution Master – Common Audio Channels and Soundfield Groups

[SMPTE ST 377-4] SMPTE ST 377-4:2012, MXF Multichannel Audio Labeling Framework

3 Remove the following Normative References

[SMPTE ST 428-3:2006] D-Cinema Distribution Master — Audio Channel Mapping and Channel Labeling

4 Replace the text of Section 8.3 ("Sound Essence Encoding") in its entirety by the following.

Sound essence tracks shall be encoded as specified in [SMPTE ST 428-2]. Section 10.3.3 and Annex A specify means of identifying the content of these essence tracks.

5 Replace the text of Annex A ("Audio Channel Assignment Label ") in its entirety by the following.

Note: Implementation behavior is undefined when a Sound Track File fails to adhere to the normative provisions specified herein.

[SMPTE ST 382] carries multi-channel PCM sound samples by using sample interleave on a channel basis. Each sample position can be thought of as a channel within the [SMPTE ST 382] container.

The number of channels within the Sound Track File shall be an even number. The inclusion of a channel of silence may be required to achieve this.

Annexes A.1 and A.2 each specifies a method for unambiguously identifying the channels present in Sound Track Files and indicating their intended reproduction location in the theater. Each method uses the ChannelAssignment property of the WaveAudioEssence Descriptor in a Sound Track File, as specified in Section 10.3.3 above.

Compliant playback devices shall use the ChannelAssignment property to identify the sound channels being used.

A.1 Static Container Channel Configurations

Each table in this Annex defines a container channel configuration that has a corresponding Universal Label (UL) for use as a value of the ChannelAssignment property. Container channels are numbered in sample packing order. The first sample is carried in container channel 1, the second in container channel 2 and so on.

The number of channels contained in a Sound Track file shall be less than or equal to the number of channels defined by the table associated with the ChannelAssignment property. However, if a given container channel is present, it shall be used according to the table. The WaveAudioEssence Descriptor ChannelCount property may be used in combination with the ChannelAssignment property to determine actual channel usage. For instance, a ChannelAssignment label indicating Channel Configuration 1 may accompany a container with a

ChannelCount value of 6, indicating that channels 7 and 8 (Hearing Impaired and Visually Impaired-Narrative) are not present.

The special case of no specified channel configuration is also provided for. See Table A.6, Channel Configuration 4. The label associated with this table shall mean “no configuration specified”. This may be used for test or experimental purposes.

Note: For the purpose of setting appropriate transport flags, implementations should not assume that all audio channels in Channel Configuration 4 contain linear PCM audio samples suitable for direct conversion to an analog audio signal.

A.1.1 Channel Label Set ULs

Table A.1 – Specification of the Channel Assignment Label when Static Container Channel Configurations are used

Byte No.	Description	Value (hex)	Meaning
1-7	Registry Designator	See SMPTE ST 400	
8	Registry Version Number	0bh	Version of SMPTE RP 224 in which this label first appears
9	Parametric	04h	Node used to define parametric data
10	Sound Essence	02h	Identifies sound essence coding
11	Sound Coding Characteristics	02h	Identifies sound coding characteristics
12	Sound Channel Labeling	10h	Identifies sound channel labeling
13	Sound Channel Labeling SMPTE ST 429-2	03h	Identifies sound channel labeling as defined in this document (SMPTE ST 429-2)
14	Channel Label Sets	01h	Identifies Static Sound Channel Label Sets
15	Channel Configuration	See Table A.2	Identifies sound Channel Configuration
16	Reserved	00h	Reserved

Table A.2 – Values for Table A.1, Byte 15

Channel Configuration	Byte 15 Value
Channel Configuration 1 (Table A.3)	01h
Channel Configuration 2 (Table A.4)	02h
Channel Configuration 3 (Table A.5)	03h
Channel Configuration 4 (Table A.6)	04h
Channel Configuration 5 (Table A.7)	05h

A.1.2 Channel Configuration Tables

Table A.3 – Channel Configuration 1

Container Channel	SMPTE ST 428-12 Name
1	Left
2	Right
3	Center
4	LFE
5	Left Surround
6	Right Surround
7	Hearing Impaired
8	Visually Impaired-Narrative

Table A.4 – Channel Configuration 2

Container Channel	SMPTE ST 428-12 Name
1	Left
2	Right
3	Center
4	LFE
5	Left Surround
6	Right Surround
7	Center Surround
8	Not Used
9	Hearing Impaired
10	Visually Impaired-Narrative

Table A.5 – Channel Configuration 3

Container Channel	SMPTE ST 428-12 Name
1	Left
2	Right
3	Center
4	LFE
5	Left Surround
6	Right Surround
7	Left Center
8	Right Center
9	Hearing Impaired
10	Visually Impaired-Narrative

Table A.6 – Channel Configuration 4

Container Channel	Name
1	CH01
2	CH02
3	CH03
4	CH04
5	CH05
6	CH06
7	CH07
8	CH08
9	CH09
10	CH10
11	CH11
12	CH12
13	CH13
14	CH14
15	CH15
16	CH16

Table A.7 – Channel Configuration 5

Container Channel	SMPTE ST 428-12 Name
1	Left
2	Right
3	Center
4	LFE
5	Left Side Surround
6	Right Side Surround
7	Left Rear Surround
8	Right Rear Surround
9	Hearing Impaired
10	Visually Impaired-Narrative

Note: Earlier revisions of this specification used terminology from [SMPTE ST 428-3], instead of [SMPTE ST 428-12], to define the mappings from container channels to audio channels. Although the mappings remain unchanged, the terms used to refer to a few of the audio channels have changed. For instance, [SMPTE ST 428-12] differentiates Side Surrounds (Lss/Rss) from Left and Right surrounds (Ls/Rs) and uses Lrs to refer to the Left Rear Surround channel, whereas [SMPTE ST 428-3] uses Rls.

A.2 Configurations using MXF Multichannel Audio Framework

When the ChannelAssignment of the WaveAudioEssence Descriptor in a Sound Track File contains the UL defined in Table A.8, the framework specified in [SMPTE ST 377-4] shall be used in conjunction with the

constraints defined in Annexes A.2.2 and A2.3 to unambiguously identify the audio channels and soundfield group carried in the Sound Track File.

Note: Items defined in [SMPTE ST 377-4] that are not specified in this section can nevertheless be present in the Sound Track File and describe particular aspects of an audio channel or soundfield group. Implementations can safely ignore these items.

The MXF Multichannel Audio Framework (MCA Framework) associates audio channels and soundfield groups contained within a D-Cinema Sound Track File with an MXF SubDescriptor that contains metadata, including a unique identifier. This enables D-Cinema implementations to properly route and process audio channels, e.g. the Hearing Impaired and Left channels may be handled by different devices. It also enables straightforward extensibility for the purpose of both experimentation and widespread use: new standalone audio channels can be defined without impacting existing soundfield groups and new soundfield groups can be introduced with minimal effort.

Figure 5 illustrates the use of the audio channel and soundfield group information contained in a Sound Track File, as specified here.

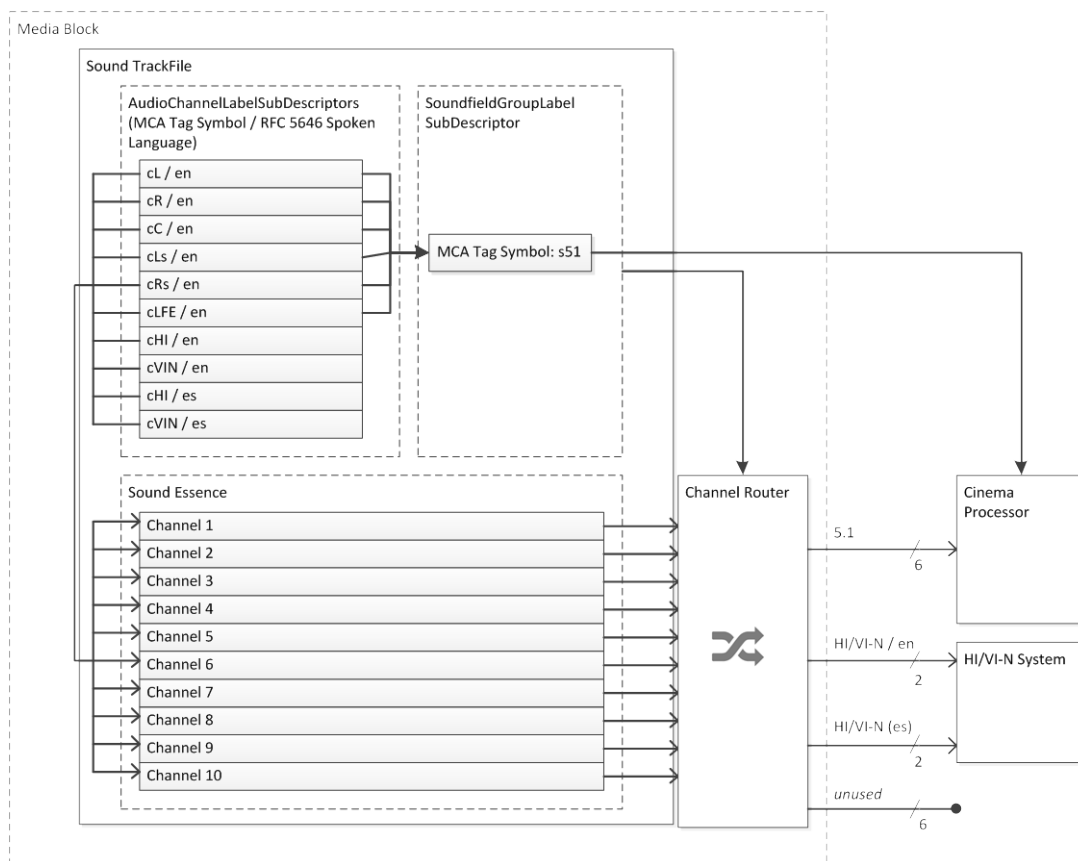

Figure 5 – Illustrative use of AudioChannelLabelSubDescriptor and SoundfieldGroupLabelSubDescriptor for a Sound Track File containing 10 audio channels consisting of a 5.1 soundfield group and associated Hearing Impaired and Visually Impaired-Narrative channels. The audio channel labeling method defined in this section is not limited to this specific channel count or soundfield configuration.

A.2.1 Configuration Channel Assignment Label

Table A.8 – Specification of the Channel Assignment Label when the MCA Framework is used

Byte No.	Description	Value (hex)	Meaning
1-7	Registry Designator	See SMPTE ST 400	
8	Registry Version Number	0D	Version of SMPTE RP 224 in which this label first appears
9	Parametric	04h	Node used to define parametric data
10	Sound Essence	02h	Identifies sound essence coding
11	Sound Coding Characteristics	02h	Identifies sound coding characteristics
12	Sound Channel Labeling	10h	Identifies sound channel labeling
13	Sound Channel Labeling SMPTE ST 429-2	03h	Identifies sound channel labeling as defined in this document (SMPTE ST 429-2)
14	D-Cinema Application of the MXF Multichannel Audio Framework	02h	Indicates that the D-Cinema Application of the MXF Multichannel Audio Framework is used
15	Reserved	00h	Reserved
16	Reserved	00h	Reserved

A.2.2 AudioChannelLabelSubDescriptor

Each audio channel contained in the Sound Track File shall be associated with zero or one AudioChannelLabelSubDescriptor instance, and each AudioChannelLabelSubDescriptor instance shall be associated with an audio channel.

Implementations shall ignore audio channels not associated with an AudioChannelLabelSubDescriptor instance. These channels should contain silence.

Note: The ChannelCount property of the Wave Audio Essence Descriptor reflects the number of channels in the Sound Track File and not the number of AudioChannelLabelSubDescriptor instances.

In addition to the items required by [SMPTE ST 377-4], the following items shall be present in every AudioChannelLabelSubDescriptor instance:

- MCA Channel ID
- MCA Tag Name
- RFC 5646 Spoken Language
- SoundfieldGroupLinkID, if and only if the audio channel referenced by the AudioChannelLabelSubDescriptor instance belongs to a soundfield group associated with a SoundfieldGroupLabelSubDescriptor instance. If present, SoundfieldGroupLinkID shall contain the MCA Link ID value of the associated SoundfieldGroupLabelSubDescriptor instance.

Not all audio channels present in a Sound Track File need to be associated with a soundfield group. For example, Hearing Impaired and Visually Impaired-Narrative channels, if present, do not belong to a soundfield group and, hence, their respective AudioChannelLabelSubDescriptor instances do not reference a SoundfieldGroupLabelSubDescriptor instance.

If an audio channel is associated with a soundfield group, then the value of their respective RFC 5646 Spoken Language items shall be equal.

A.2.2.1 Common D-Cinema Channels

Implementations shall recognize the common D-Cinema audio channels defined in Table 1 of [SMPTE ST 428-12].

The presence of such an audio channel shall be indicated by an AudioChannelLabelSubDescriptor instance whose MCA Label Dictionary ID value is equal to a UL value defined by the combination of column 1 of Table 1 and Table 2 of [SMPTE ST 428-12].

The MCA Tag Name of such an AudioChannelLabelSubDescriptor instance shall be equal to the Name (as specified in [SMPTE ST 428-12]) of the audio channel associated with the UL value.

The MCA Tag Symbol item of such an AudioChannelLabelSubDescriptor instance shall be constructed by prepending the string "ch" to the Symbol (as specified in [SMPTE ST 428-12]) of the audio channel associated with the UL value.

No channel listed in Table 1 of [SMPTE ST 428-12] shall appear more than once in a given Sound Track File with the exception of Hearing Impaired and Visually Impaired-Narrative channels. If there are multiple Hearing Impaired or Visually Impaired-Narrative channels in a Sound Track File, they shall be distinguished by the value of their RFC 5646 Spoken Language item.

Furthermore, the RFC 5646 Spoken Language item shall not have the same value in two or more audio channels labeled Hearing Impaired, and the RFC 5646 Spoken Language item shall not have the same value in two or more audio channels labeled Visually Impaired-Narrative.

A.2.2.2 Extension Channels

For extensibility, channels not defined in Table 1 of [SMPTE ST 428-12] may be present.

Implementations shall not automatically pre-assign an audio channel with an AudioChannelLabelSubDescriptor instance having a MCA Label Dictionary ID that the implementation does not recognize and, for the purpose of setting appropriate transport flags, should not assume that such an audio channel contains linear PCM audio samples suitable for direct conversion to an analog audio signal.

Implementations may display to the user channels associated with an MCA Label Dictionary ID they do not recognize and offer the user the option to take action on such a channel based on the MCA Tag Name, MCA Tag Symbol and RFC 5646 Spoken Language of the AudioChannelLabelSubDescriptor instance that references it.

A.2.3 SoundfieldGroupLabelSubDescriptor

There shall be one and only one SoundfieldGroupLabelSubDescriptor instance in the Sound Track file.

In addition to the items required by [SMPTE ST 377-4], the following items shall be present in the SoundfieldGroupLabelSubDescriptor instance:

- MCA Tag Name
- RFC 5646 Spoken Language

A.2.3.1 Common D-Cinema Soundfield Groups

Implementations shall recognize the common D-Cinema soundfield groups listed in Table 3 of [SMPTE ST 428-12].

The presence of such a soundfield group shall be indicated by SoundfieldGroupLabelSubDescriptor instance whose MCA Label Dictionary ID value is equal to one of the UL values defined by the combination of column 1 of Table 3 and Table 4 of [SMPTE ST 428-12].

The MCA Tag Name of such a SoundfieldGroupLabelSubDescriptor instance shall match the value of the Name of the soundfield group (as specified in [SMPTE ST 428-12]) associated with the UL value.

The MCA Tag Symbol item of such an SoundfieldGroupLabelSubDescriptor instance shall be constructed by prepending the string "sg" to the Symbol of the soundfield group (as specified in [SMPTE ST 428-12]) associated with the UL value.

Not all channels listed in the "Audio Channels" column of a given soundfield group in Table 3 of [SMPTE ST 428-12] need to be present in the sound track file, but only those channels listed in the "Audio Channels" column for a given soundfield group may reference that SoundfieldGroupLabelSubDescriptor instance. Furthermore, if a channel is listed in the "Audio Channels" column of a given soundfield group but absent in the Sound Track File, then implementations shall assume the channel was not intended for reproduction by the content provider.

Note: Implementations may indicate to the user if a channel listed in the "Audio Channels" column for a given soundfield group is not present.

A.2.3.2 Extension Soundfield Groups

For extensibility, soundfield groups not defined in Table 3 of [SMPTE ST 428-12] may be present. However, implementations shall take no action with a SoundfieldGroupLabelSubDescriptor instance having a MCA Label Dictionary ID that the implementation does not recognize or if a channel that is not listed in the "Audio Channels" column for a given soundfield group references that SoundfieldGroupLabelSubDescriptor instance.

Note: Implementations can use the SoundfieldGroupLabelSubDescriptor instance for display to the user and to appropriately configure the B-Chain for the intended soundfield reproduction.